

HYDRAULIC DIRECTIONAL CONTROL VALVES РАСПРЕДЕЛИТЕЛИ ГИДРАВЛИЧЕСКИЕ



Description

Назначение и область применения:

For starting, controlling and stopping the working fluid between the generator of pressured flow, the consumers and the Tank. Предназначены для изменения направления потока, ограничения давления рабочей жидкости в гидролиниях, разгрузки насоса в нейтральной позиции золотников.

Specifications

Основные показатели:

1. Valve monoblock	моноблок
Конструктивное исполнение	2 bolts M8
2. Mounting	
Крепление	
3. Pressure connections	internal thread
При соединительные отверстия	внутренние резьбы
4. Ambient temperature	-40C...+60C
Температура воздуха	
5. Pressure medium	mineral oil based hydraulic oil
Рабочая жидкость	
6. Viskosity	12...800 mm ² /s permissible range
Кинематическая вязкость	20...100 mm ² /s recommended range
7. Fluid temperature	-15C...+80C
8. Filtration	Oil contamination 10 to NAS1638
9. Max. operating pressure	P = 250 bar
Давление max. bar	T = 50 bar
	A, B = 300 bar
	7 cm ³ /min at 100 bar
10. Internal (46 mm ² /s) Leakage	
Внутренние потери (A, B - T)	
11. Nominal flow	40 l/min (see "operating" diagram)
Разход рабочей жидкости	
12. Spool stroke	±6 mm
Ход золотника	
13. Actuating force	< 200 N in spool axis direction
Усилие на движения золотника	



Left hand configuration - standart

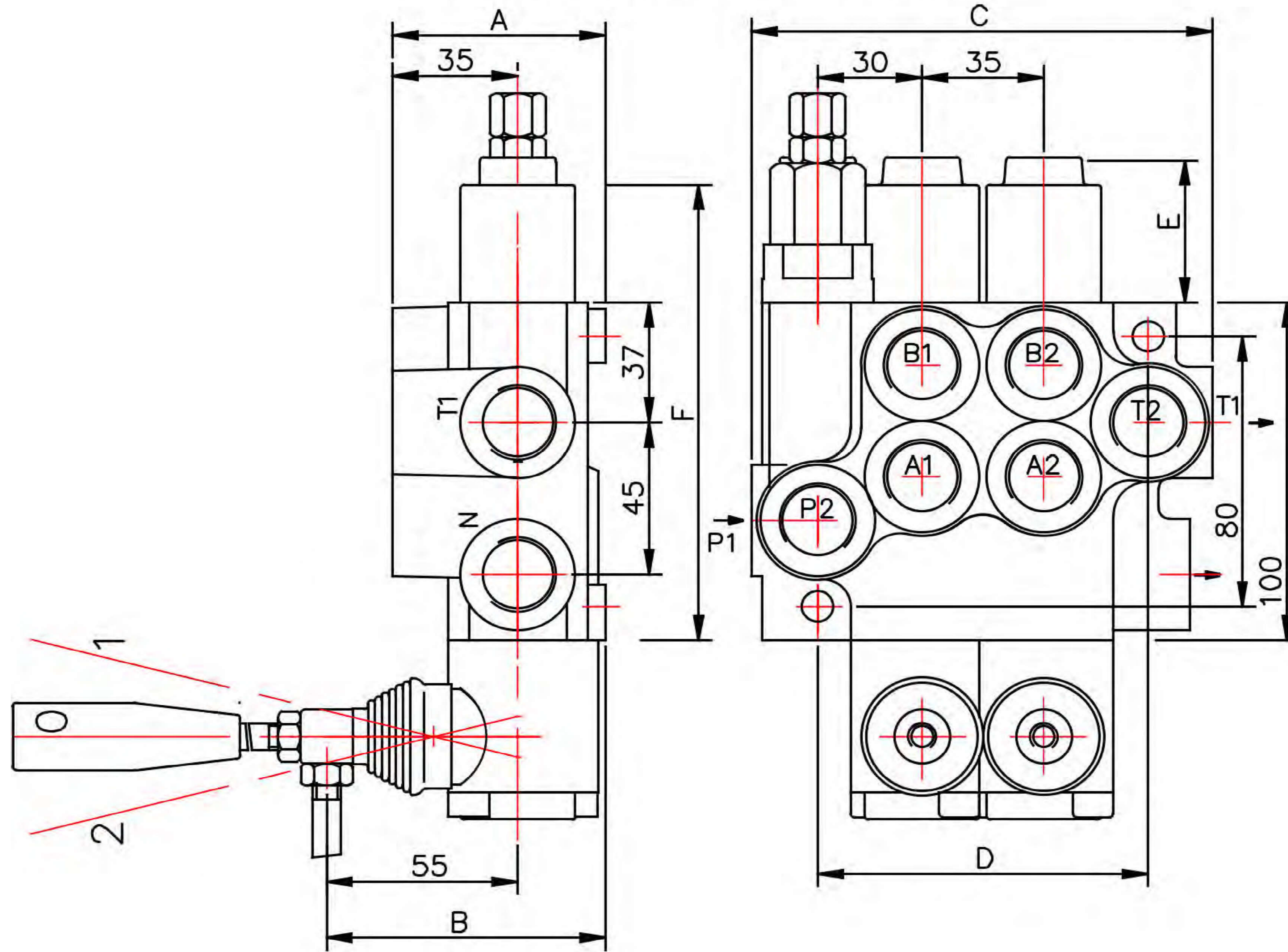

Right hand configuration

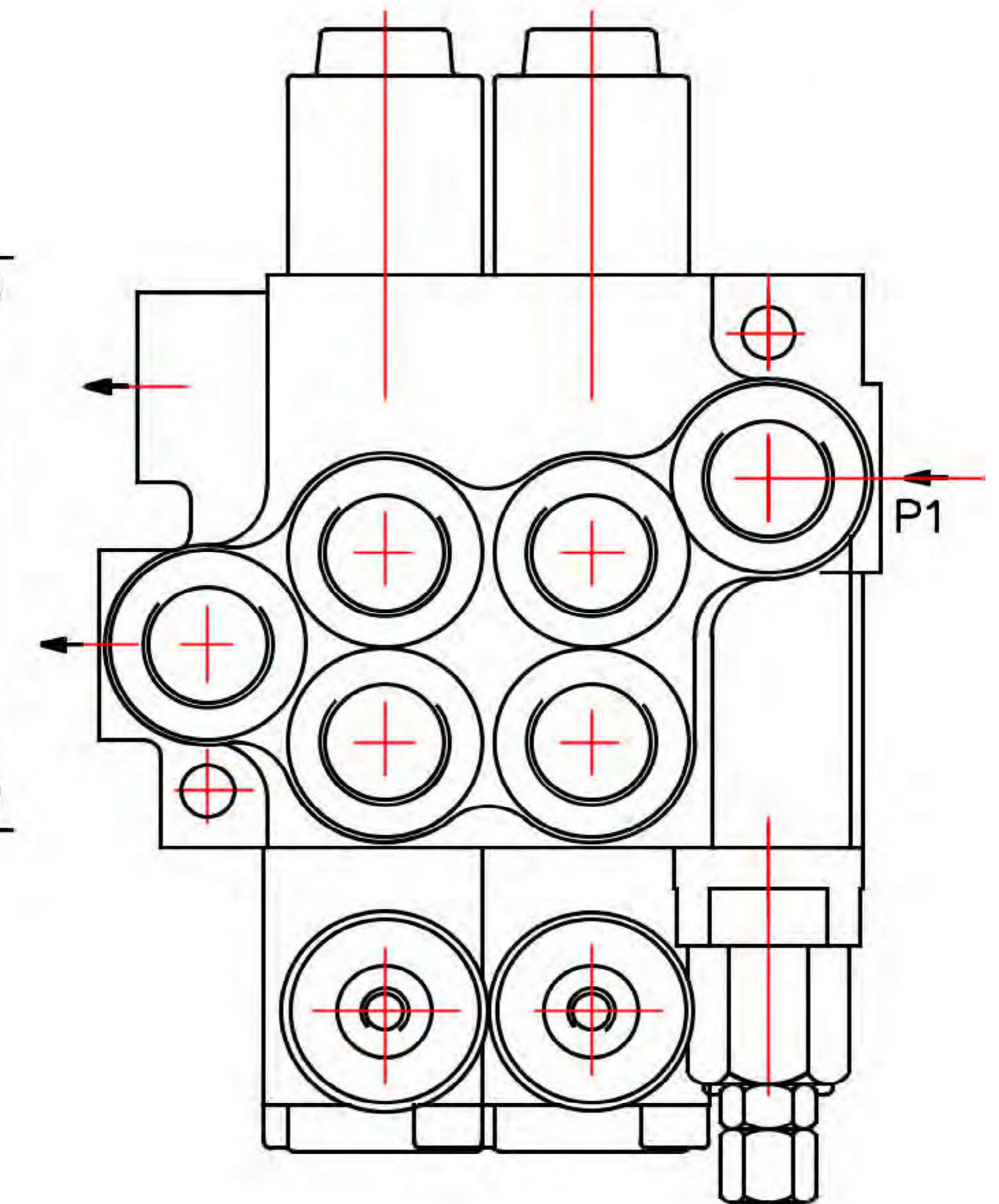

Table 1

	A	B	C	D	P1	P2	T1	T2
P40	60	80	85	60	+	-	+	-
02P40	60	80	129	97	+	+	+	+
03P40	60	80	164	132	+	+	+	+
04P40	60	80	199	167	+	+	+	+
05P40	60	80	234	202	+	+	+	+
06P40	60	80	269	237	+	+	+	+
07P40	60	80	304	272	+	+	+	+
2P40	60	80	129	97	+	+	+	+
3P40	60	80	164	132	+	+	+	+
4P40	60	80	199	167	+	+	+	+

Table 2

spool control фиксация золотника	E	F
1; 4; 5; 6; 7; 8; 9; 10; 11;	40	193
2; 3;	72	225
16	+	+

0 2 P40R

block with common check valve
распределитель с общим клапаном

number of spools
количество золотников

directional control valve type ...
распределитель типа ...

inlet high pressure - right
вход давления с правой стороны

relief valve; - standard setting 175 bar;
(svr) relief valve blanking plug; без предопр. клапана
(4) Spring for 160 to 315 bar; standard setting 220 bar;

way of distribution/parallel or .../
способ распределения потока

first spool distribution type
характеристика первого золотника

spool control/detend and estr./
контроль золотника/фиксации и сгрузки/

second spool distribution type
тип второго золотника

spool control/detend and estr./
контроль золотника/фиксации и сгрузки/

ports /treads/
резьбовые отверстия

general operation feature
тип ручного управления

with "teton"
исполнение ручного управления с "тетон"

operation feature /pneumatic, .../
с грузое управление

with electric switch
с электрическим выключателем

high pressure carry over
продолжитель потока высокого давления

connection ports in use
присоединительные отверстия

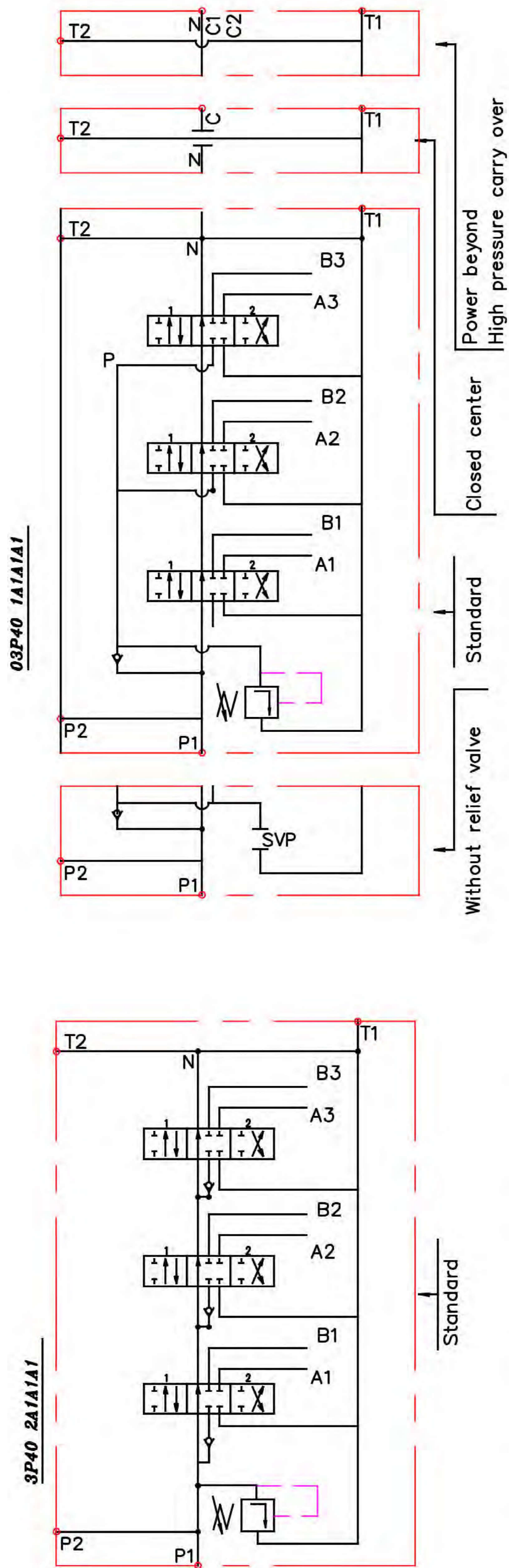

Table 3







code	Number of spools
	1
02, 2	2
03, 3	3

ets.

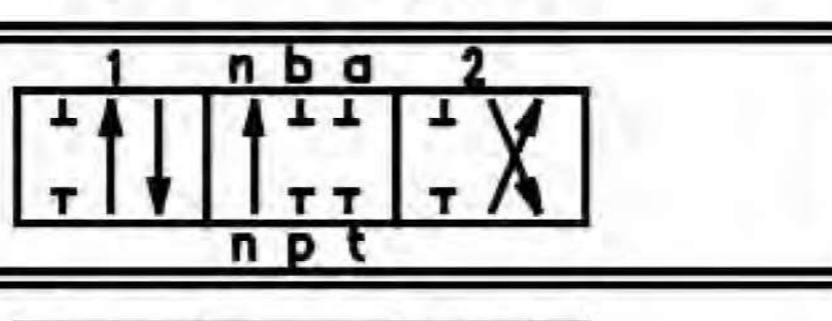
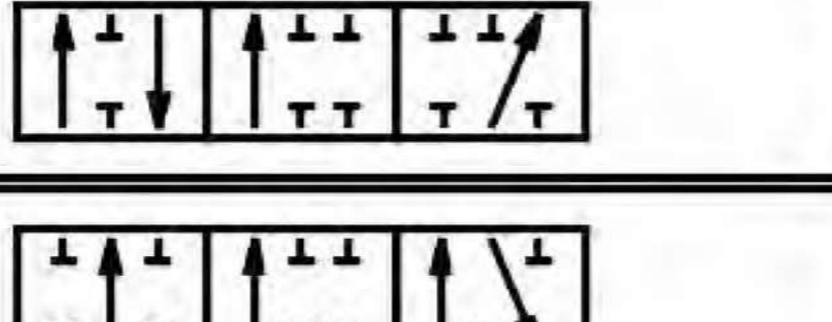
Table 4

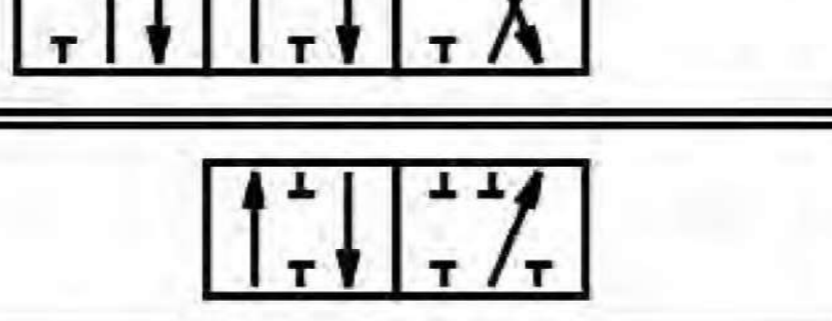
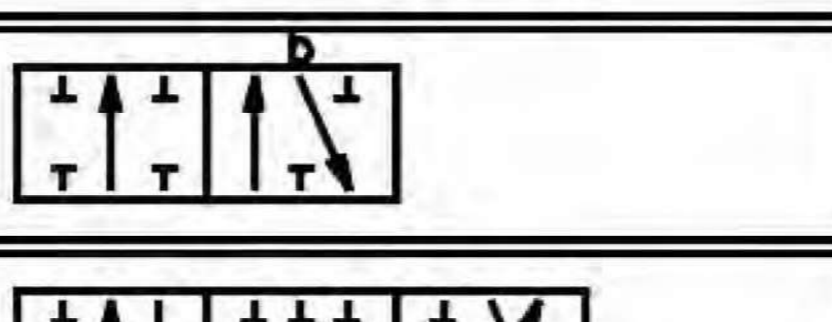
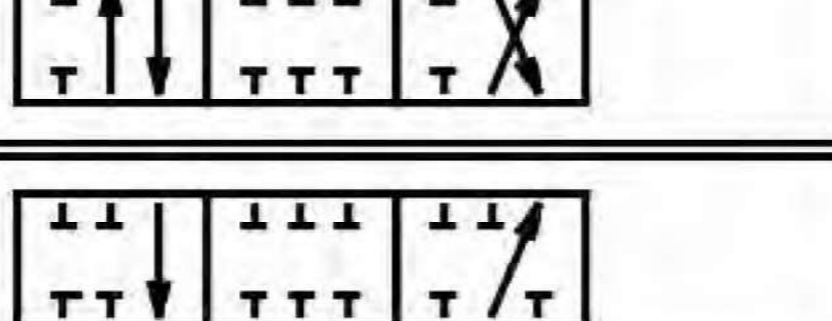
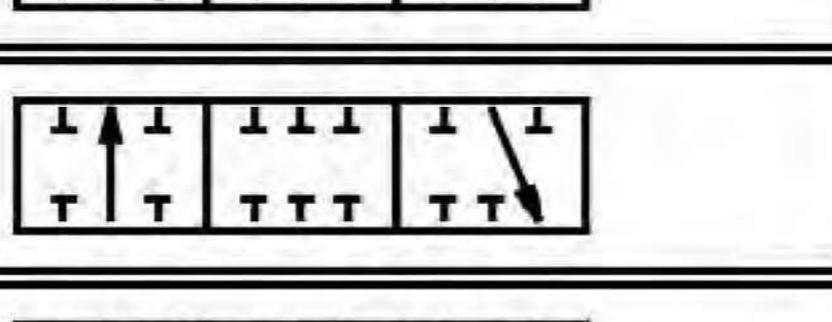
code	way of distribution ; распределение потока
1	parallel ; параллельное
2	tandem(series parallel) ; серийно-параллельное

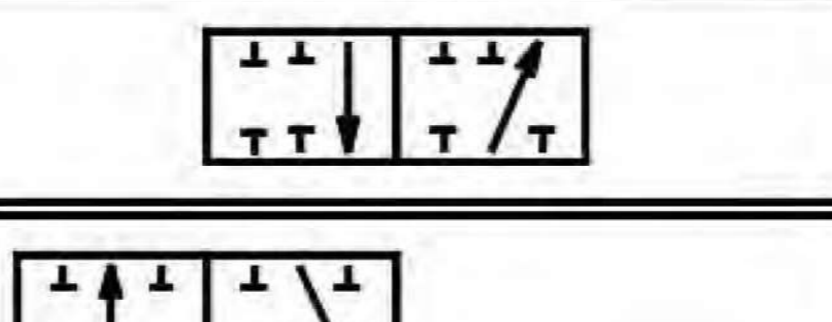
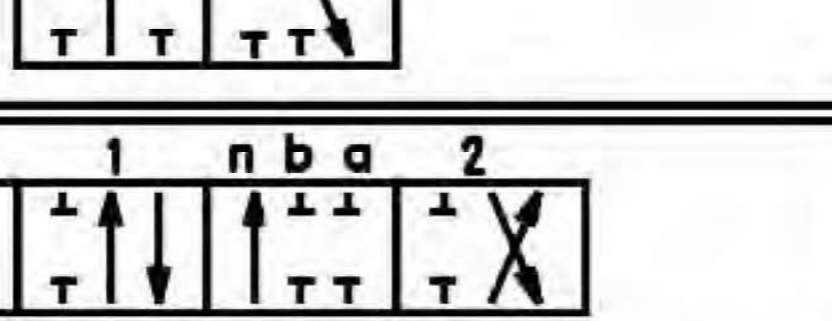
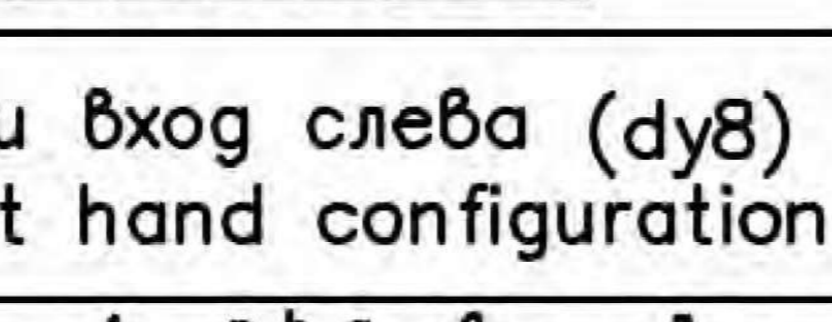
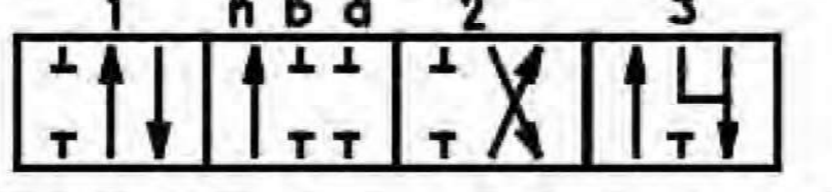
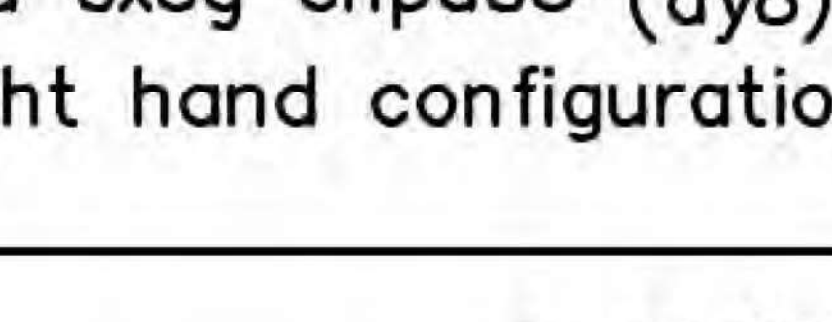
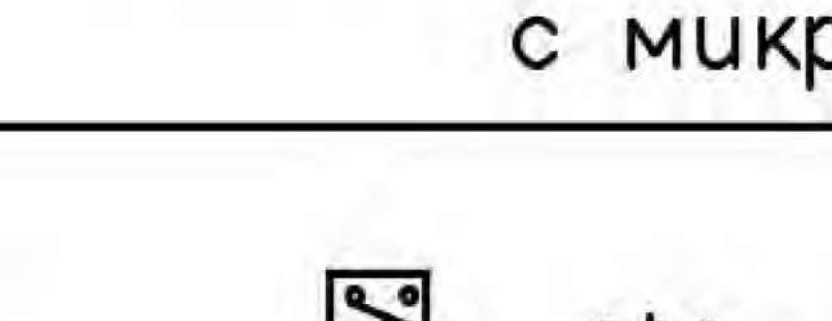
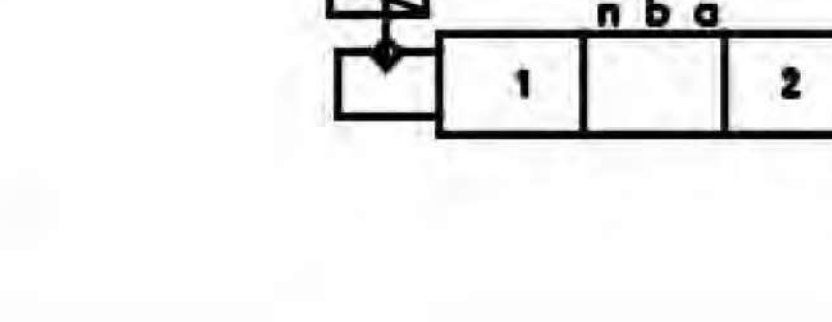
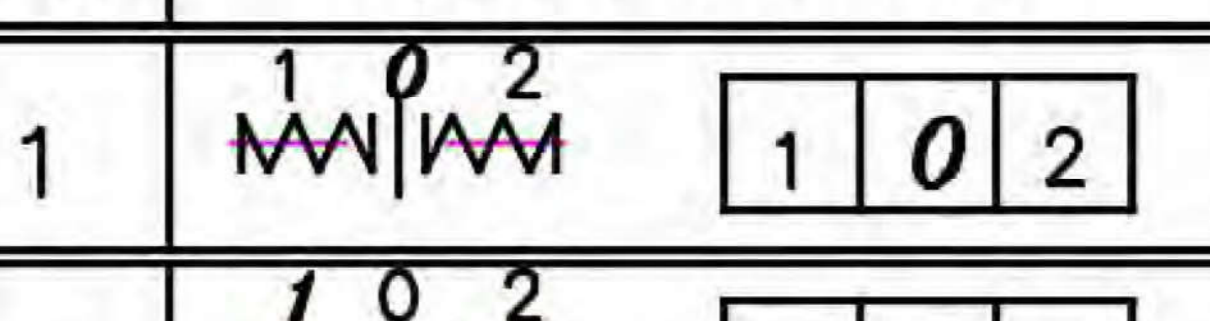
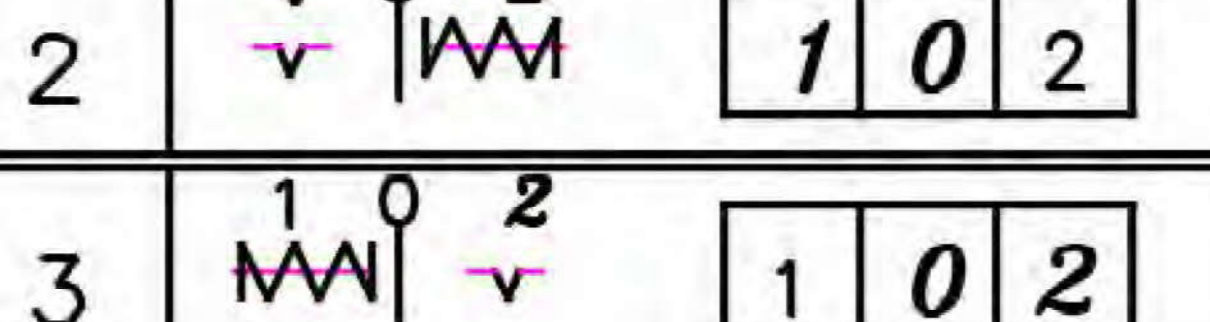
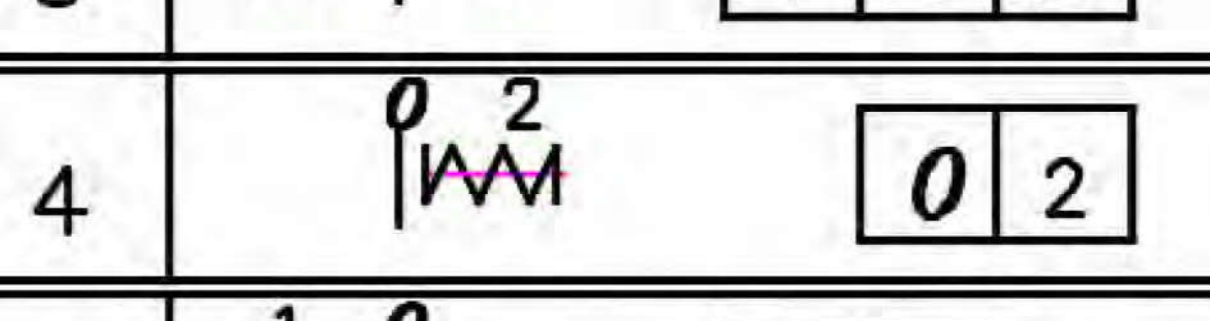
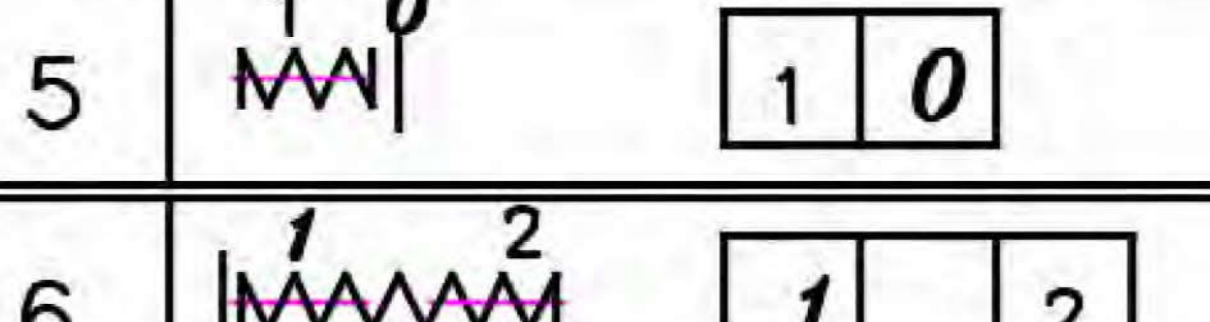
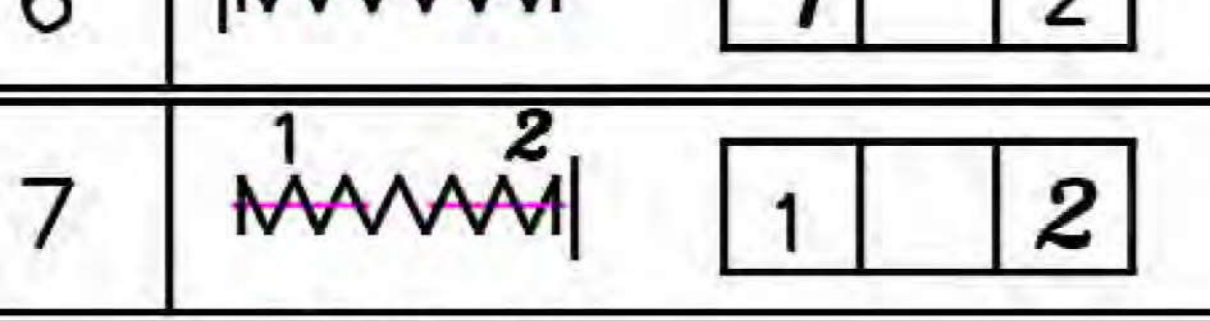
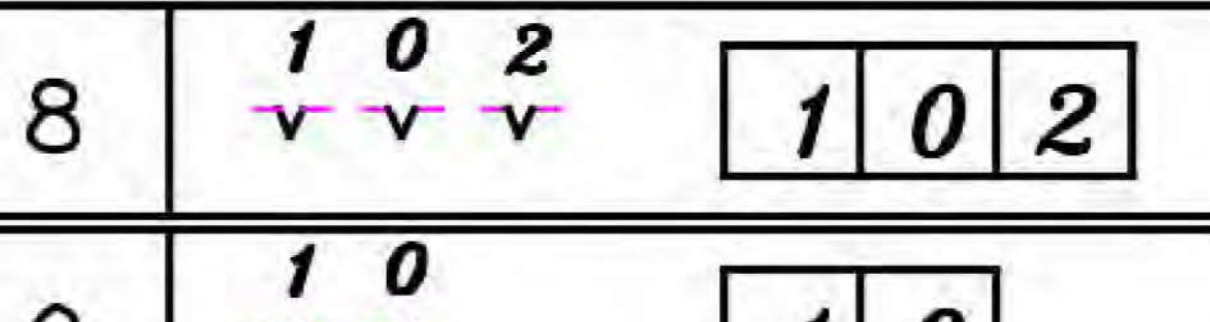
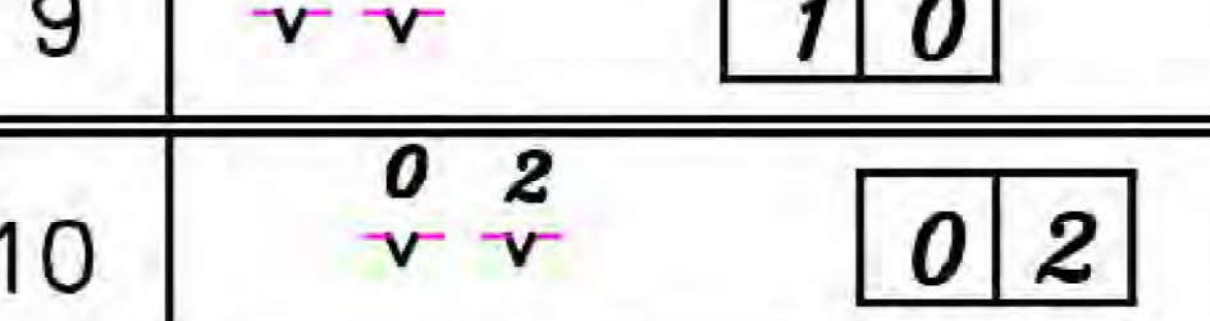
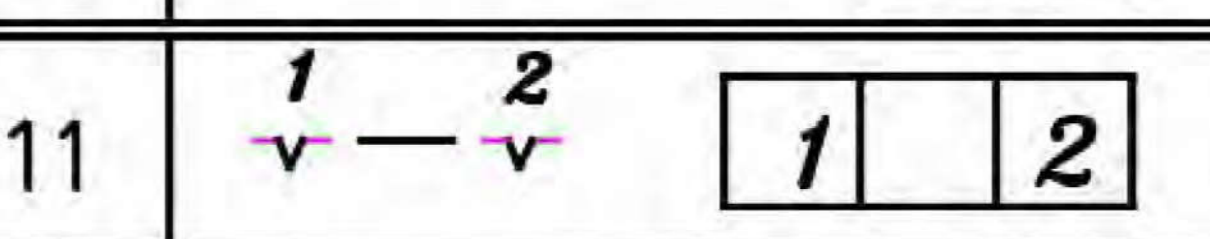

Table 5

code	spool type
A	
B	
C	
D	
E	
F	
G	
H	
M	
N	
O	
P	
Q	
R	
S	
T	
* K	
** L	

* только при вход слева (dy8) only for left hand configuration

** только при вход справа (dy8) only for right hand configuration

Table 6

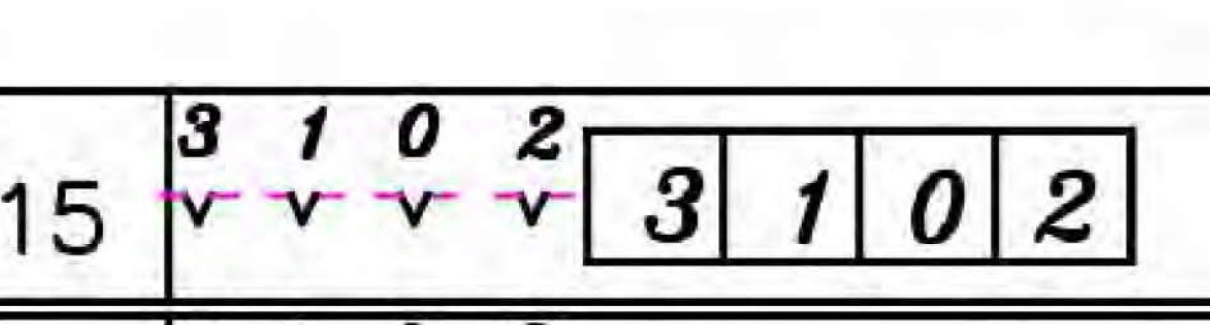
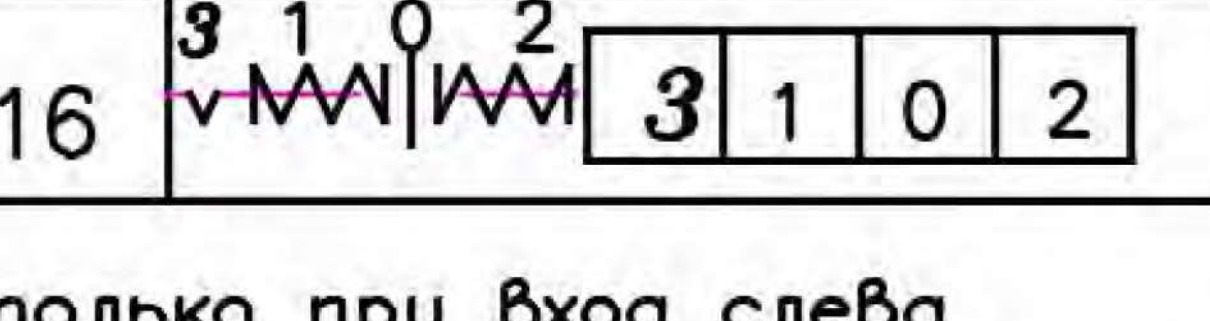
code	spool control
1	
2	
3	
4	
5	
6	
7	
8	
9	
10	
11	

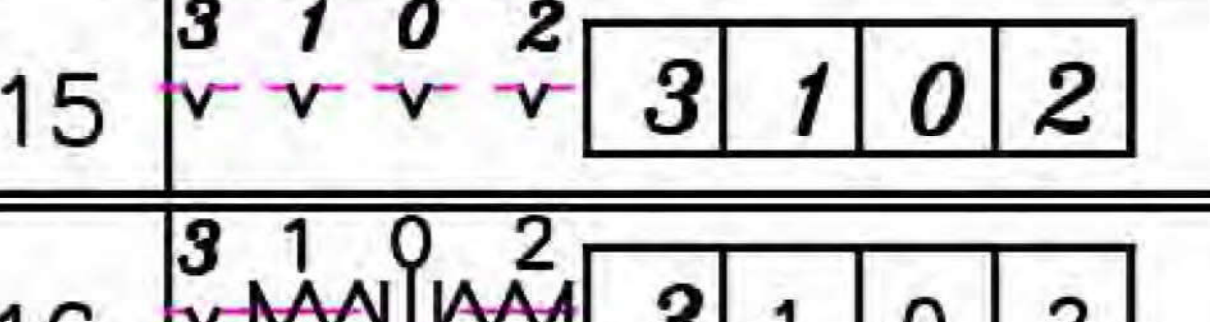
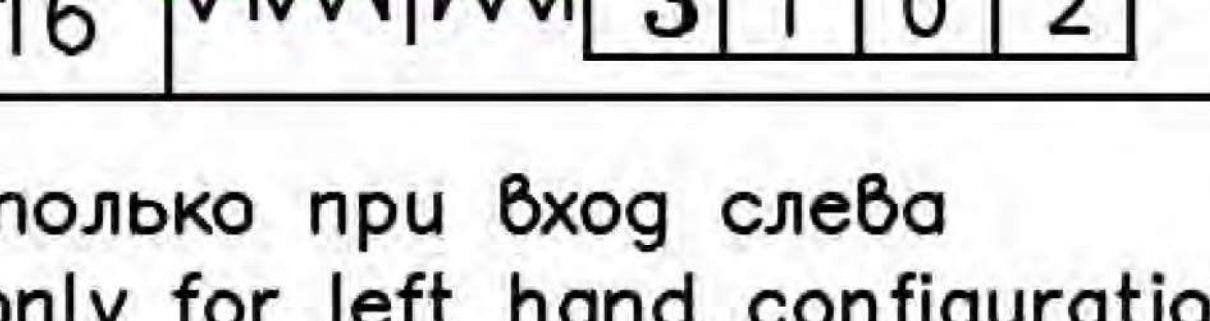
* 15	
* 16	

* только при вход слева only for left hand configuration

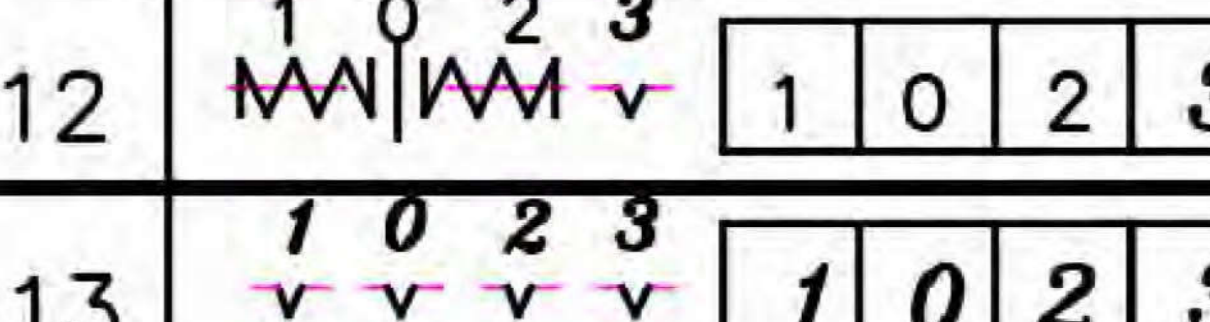
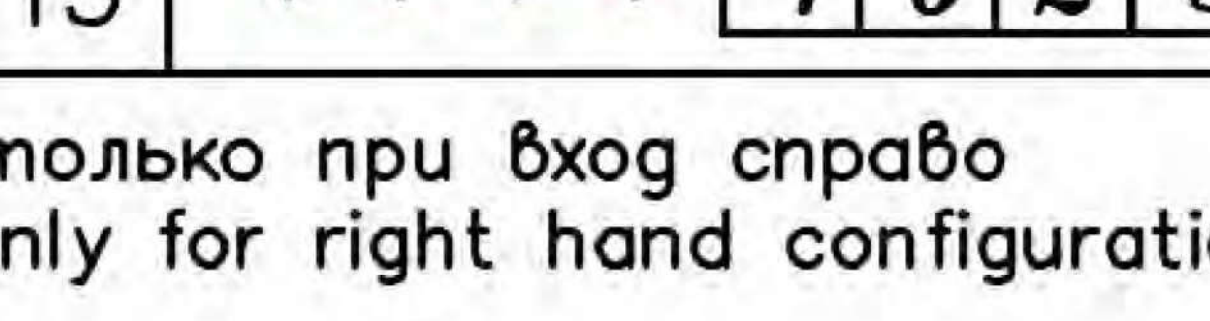
** 12	
** 13	

** только при вход справа only for right hand configuration

Table 7

code	с микро шалпер ; incorporated microswitch	
E		mikroswitch type Omron-V 165 I C5 

Table 8

code	другое управление ; operation feature	
P		пневматическое on-off pneumatic control; 5-10 bar ; ports NPTF 1/8-27
H		гидравлическое on-off hydraulic control ; pn = 5 - 20 bar ; ports G1/4



P40 directional control valve

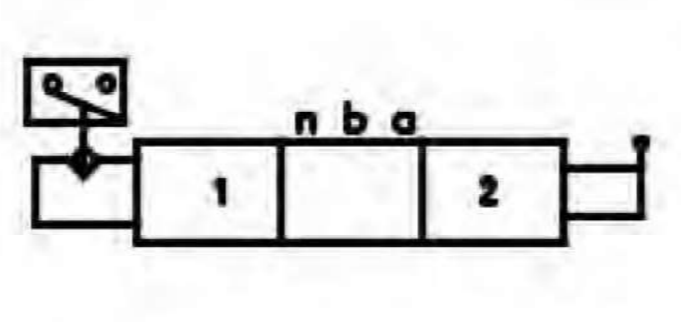
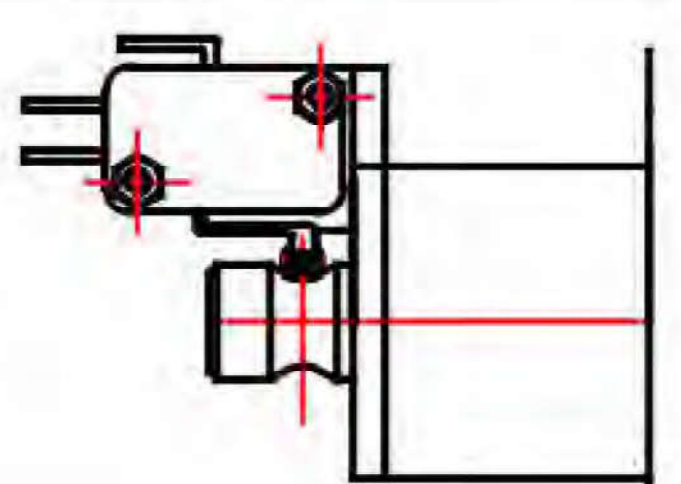
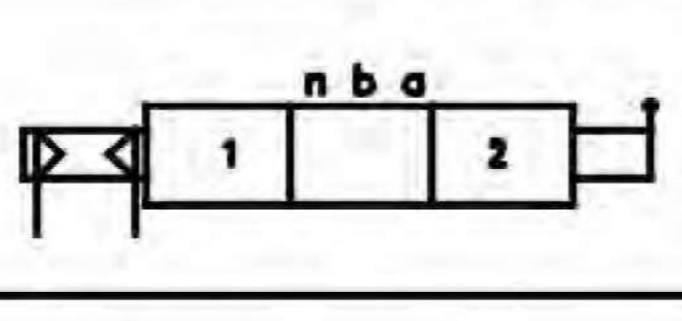
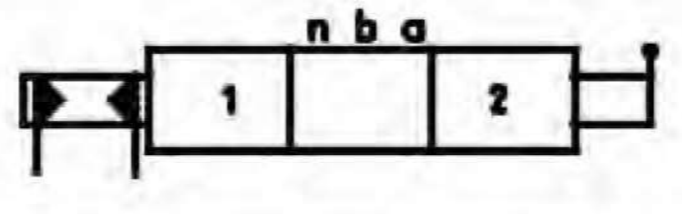
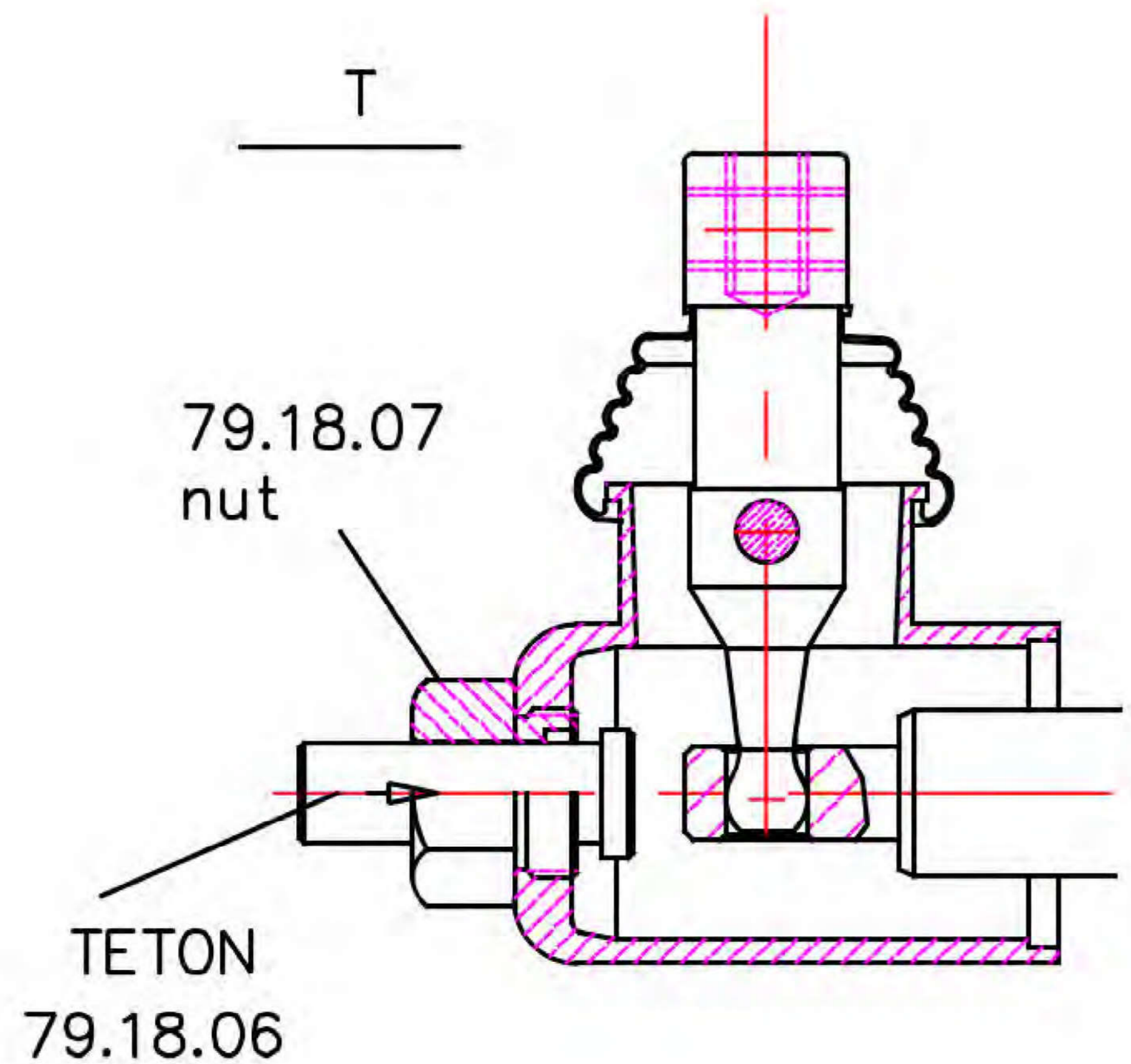
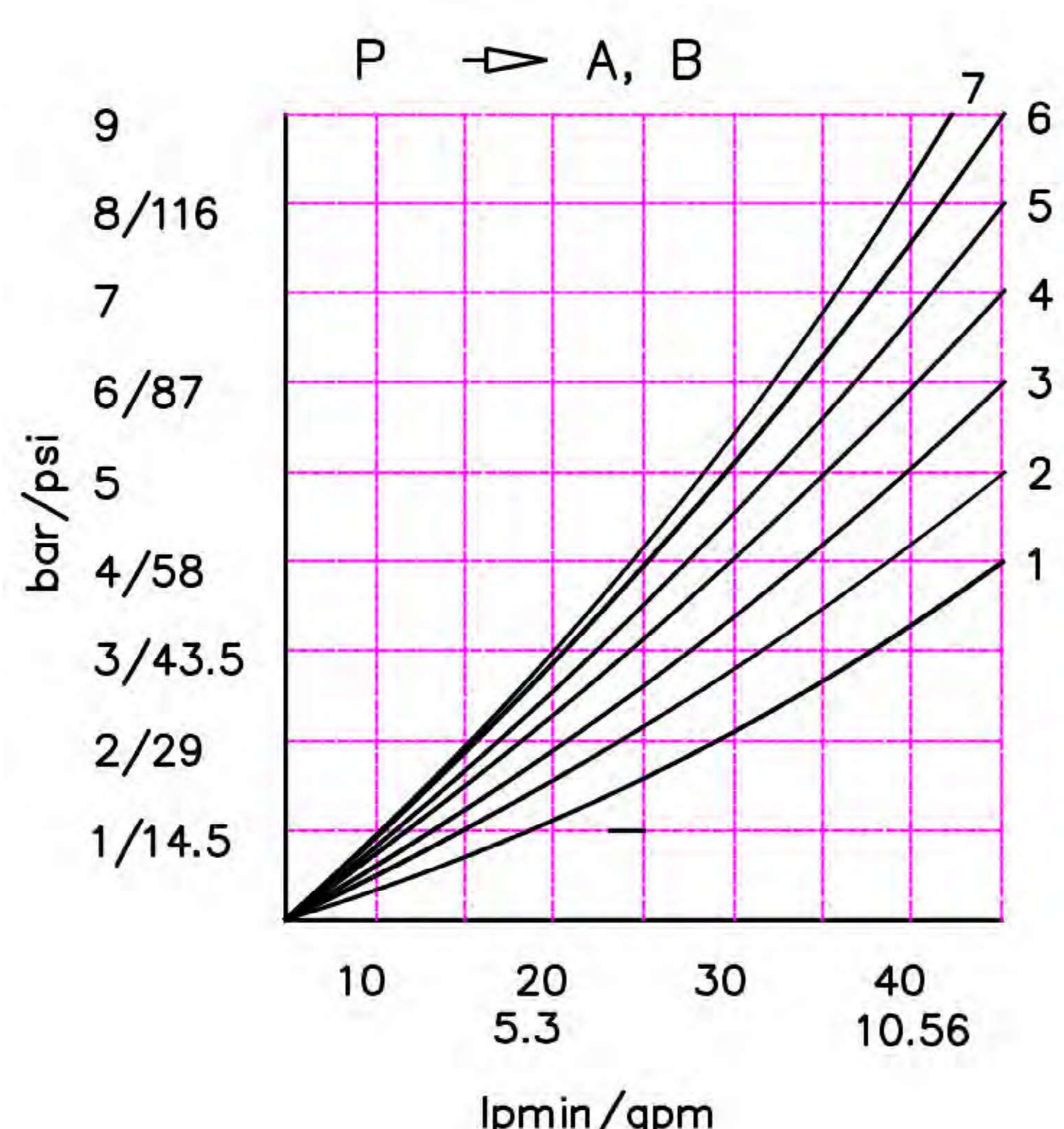
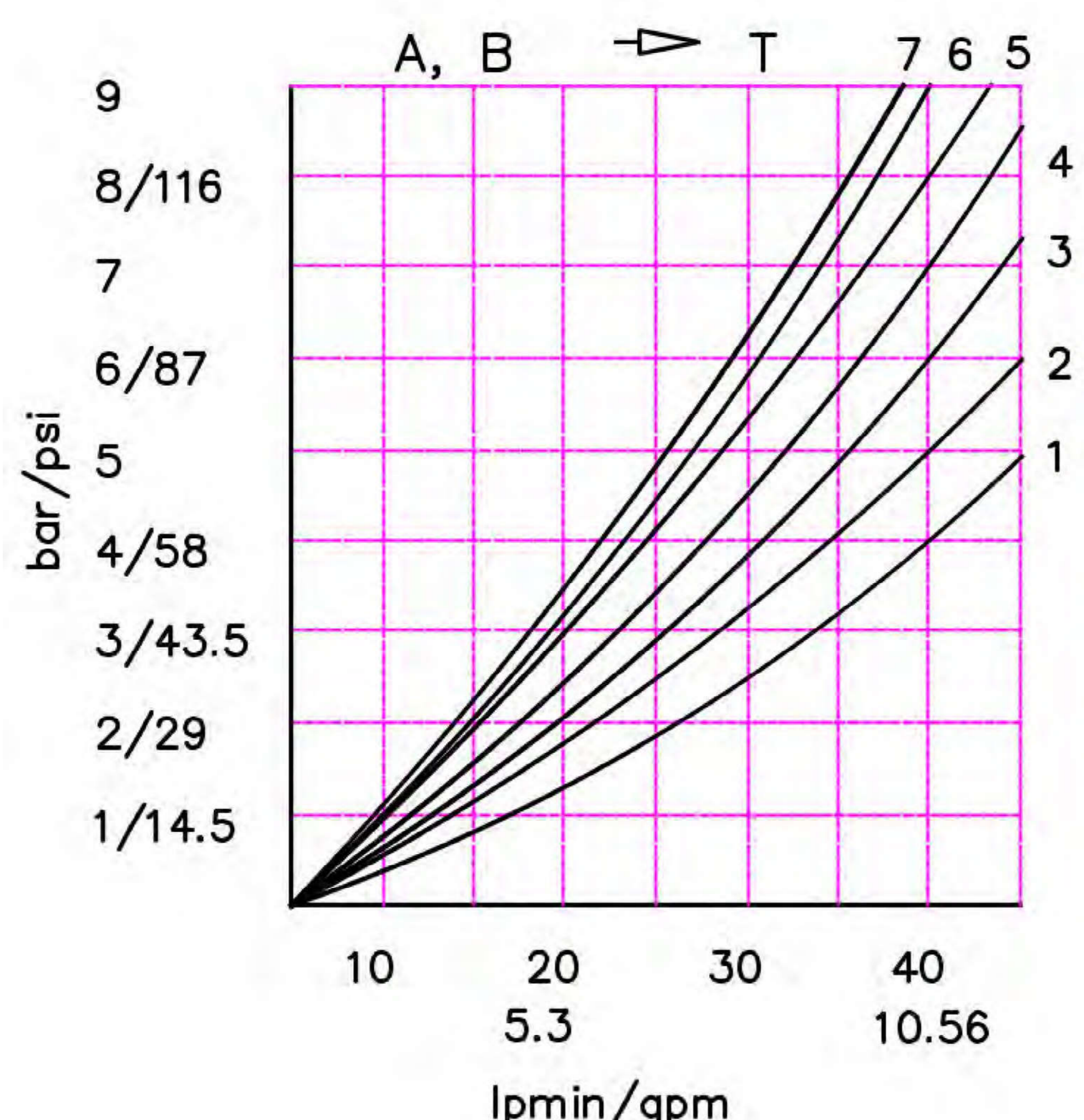
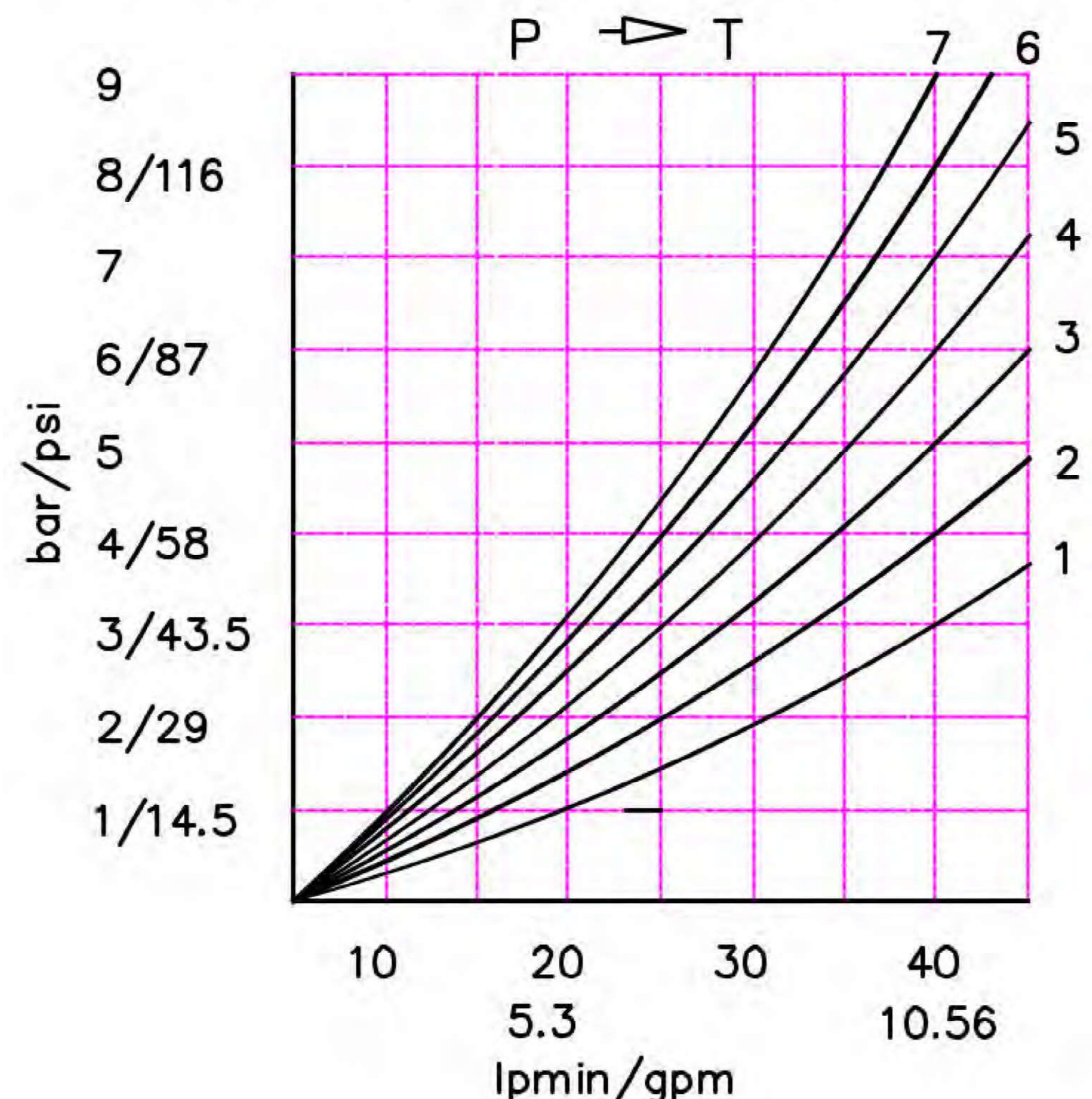

P40 Table 9

code ports (threads) ; присоединительные отверстия

	P	A ; B	T	N
M	M22x1.5	M18x1.5	M22x1.5	M22x1.5
G	G1/2	G3/8	G1/2	G1/2
G1/2	G1/2	G1/2 on request	G1/2	G1/2
S	7/8-14UNF	3/4-16UNF	7/8-14UNF	7/8-14UNF

kind of hand control ; вид ручного управления Table 10

code	ескюз feature	code	ескюз feature	code	ескюз feature
KZ		KY		KI	
KZ1		KY1		KI1	
KZ0		KY0		KI0	
KZ01		KY01		KI01	
-	without hand control ; без лостова система за управление				

Table 11

code	вид продължение на дебита	
C	отвор "N" затворен closed center	
C1	отвор "N" продължава за следващ консуматор part for power beyond sleeve (carry over)	 $\varnothing 14 \text{ mm}$ M22x1.5
C2	отвор "N" продължава за следващ консуматор part for power beyond sleeve (carry over)	 G 1/2 M22x1.5
-	отвор "N" е свързан с "T" without part for pressure carry over	
X	отвор "N" е винаги свързан с "T" power beyond ever to tank	

Table 12

code	used connection ports ; присоединительные отверстия
11	P1 ; T1
12	P1 ; T2
21	P2 ; T1
22	P2 ; T2

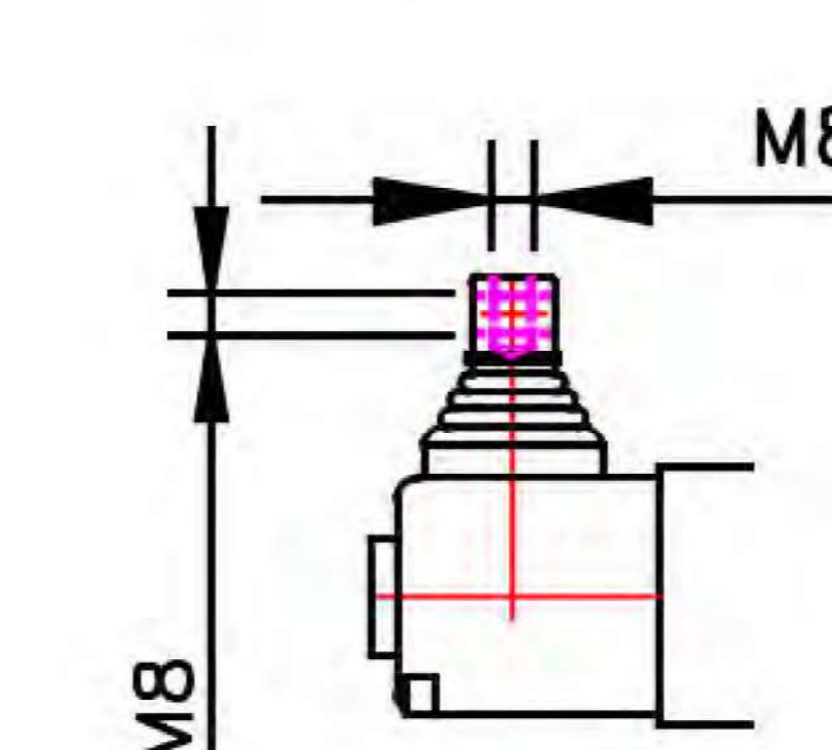
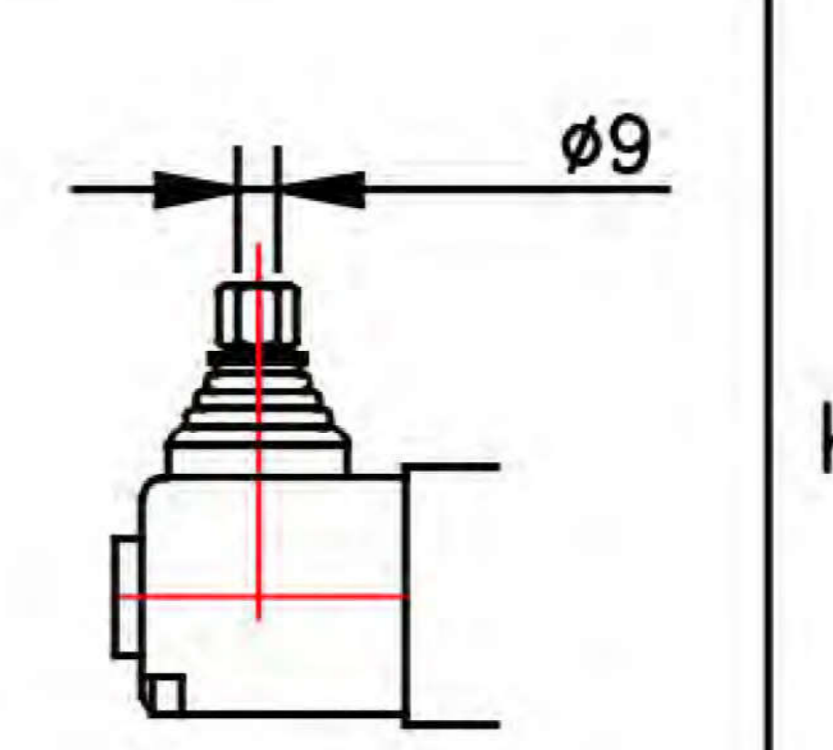
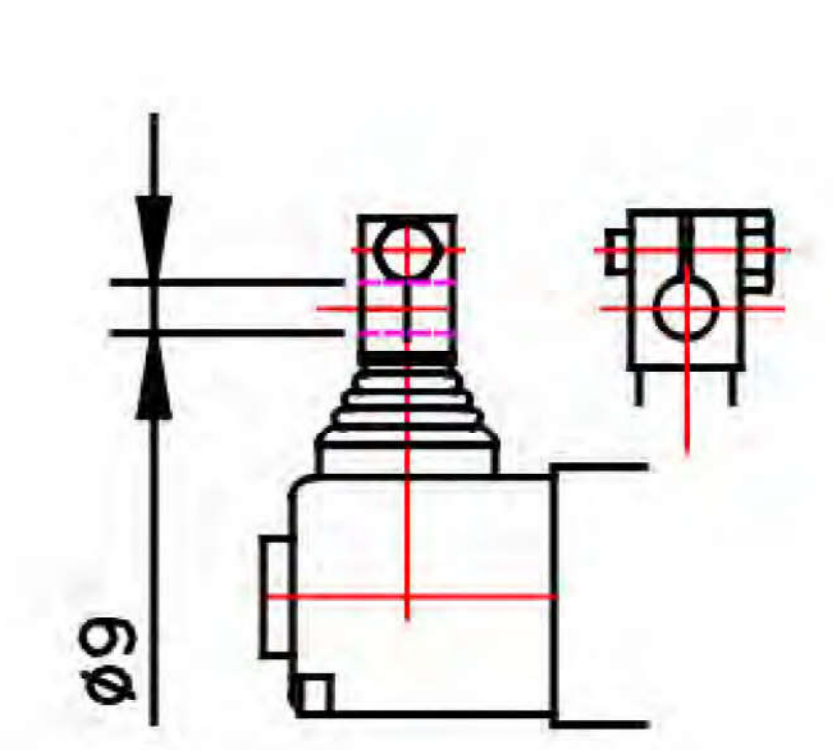
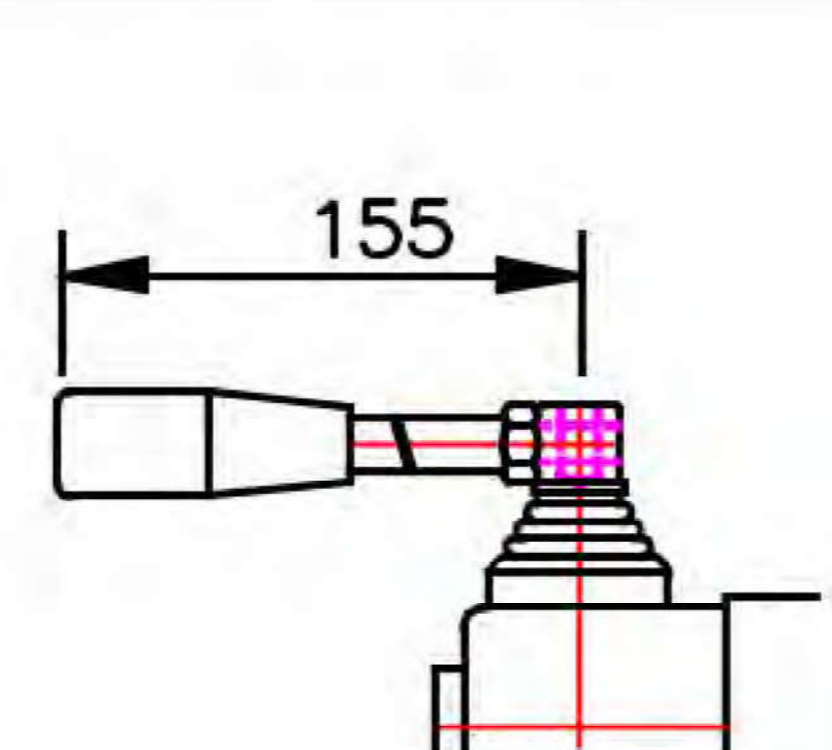
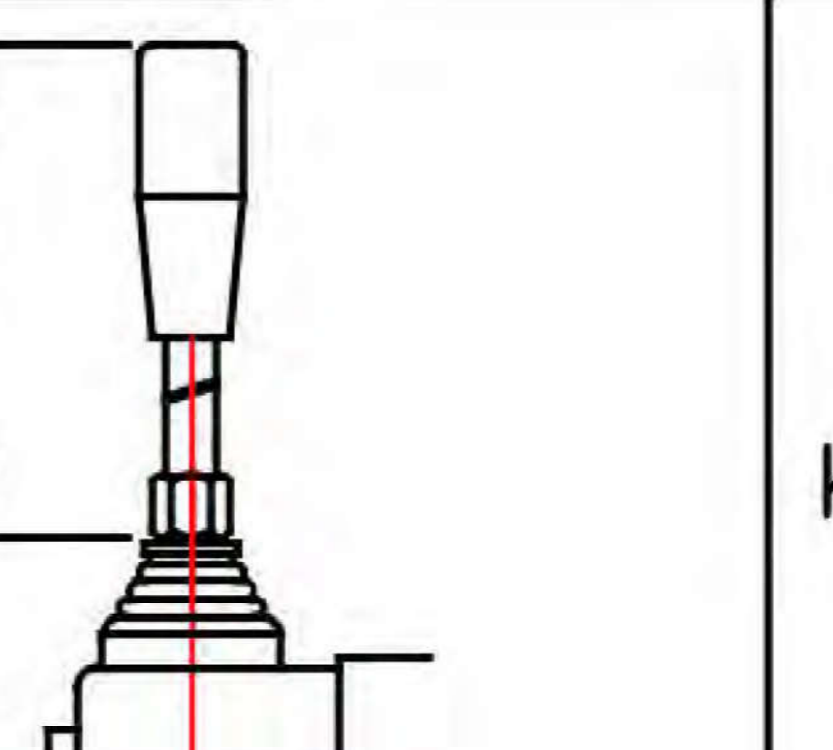
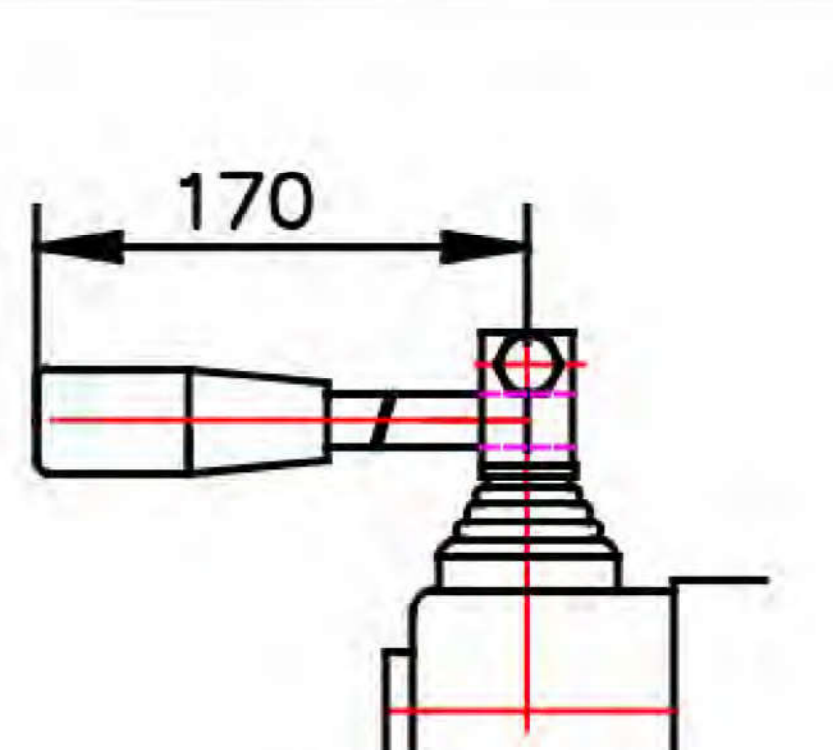
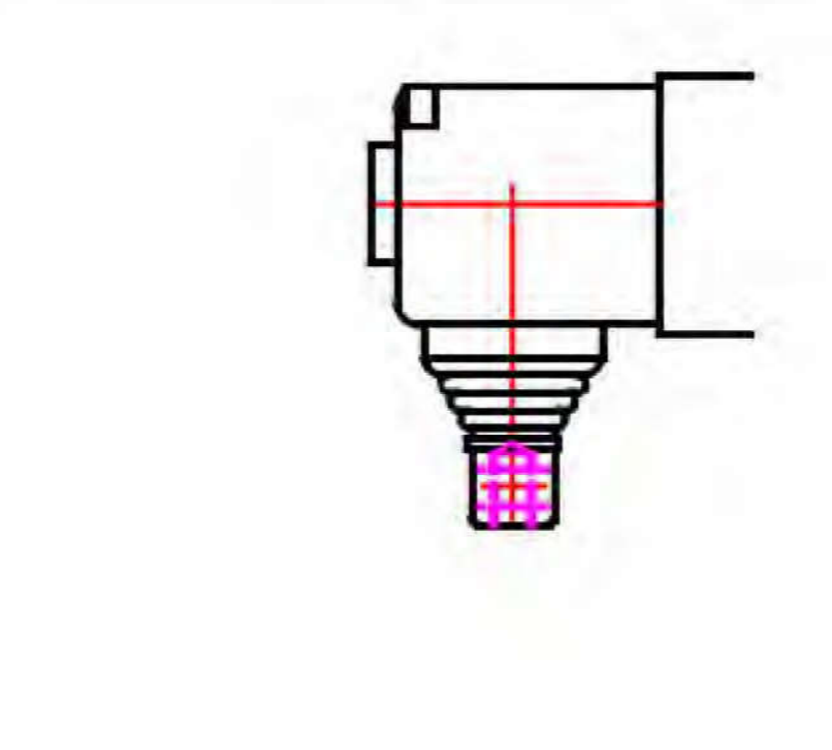
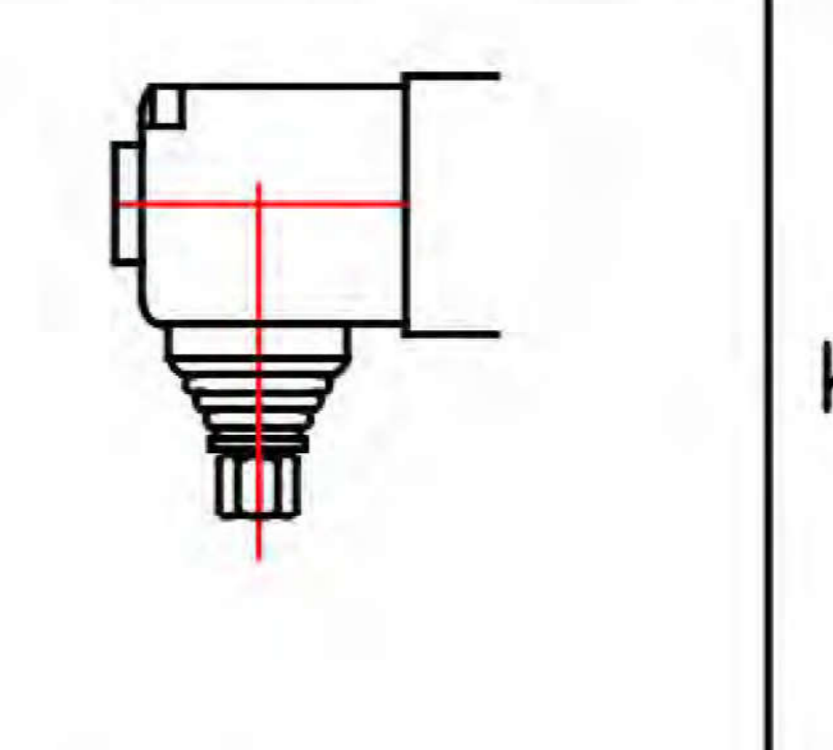
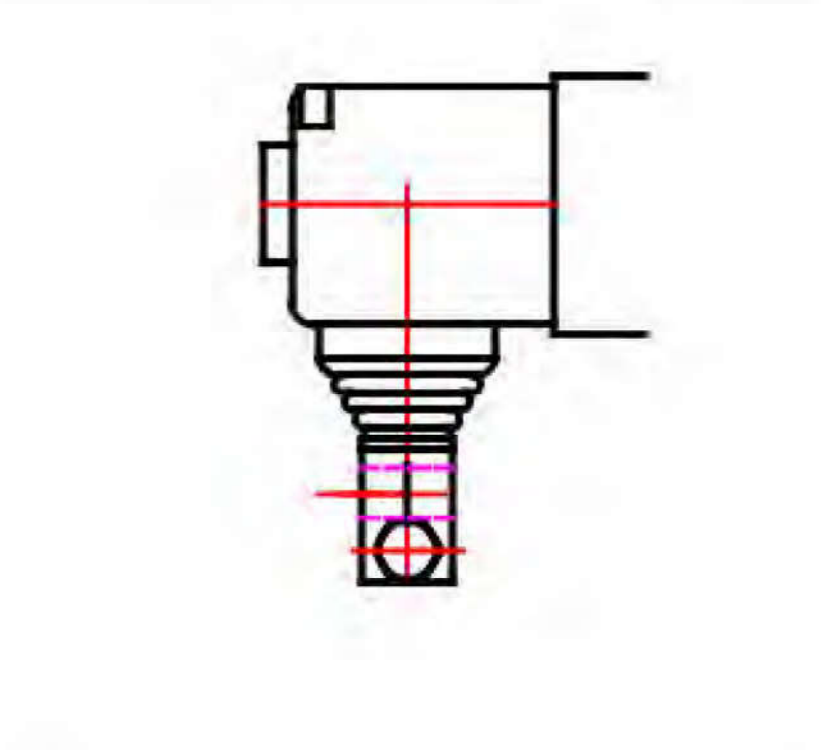
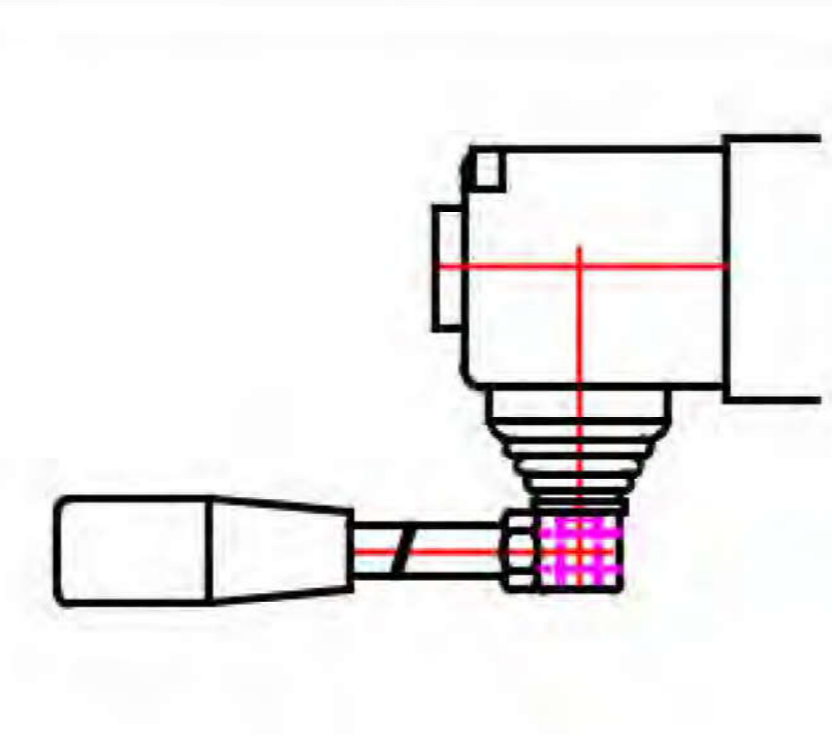
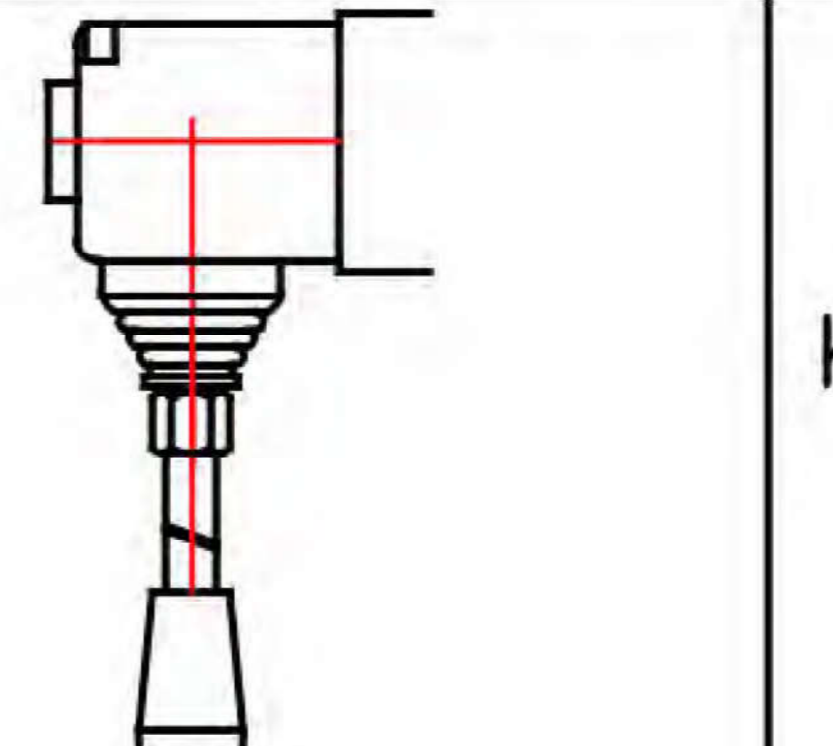
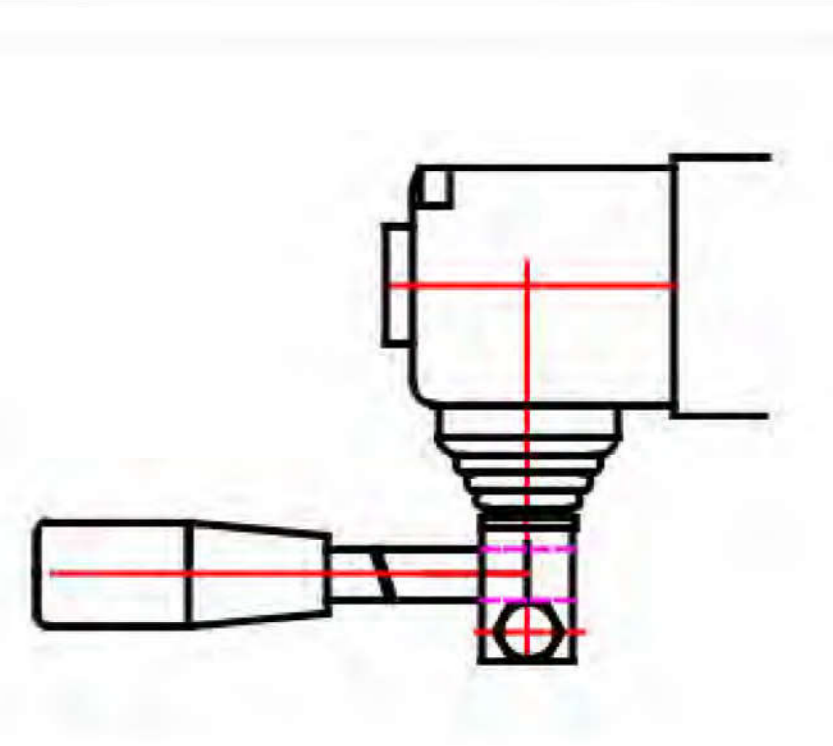

REMOTE CONTROLS Управление тросом

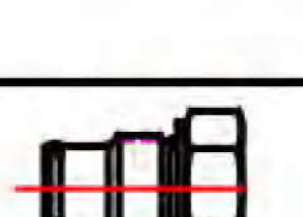
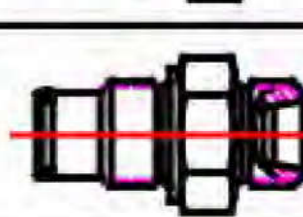
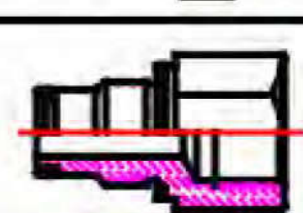
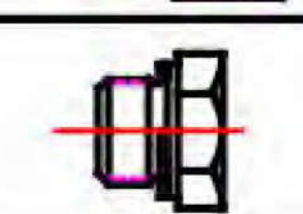
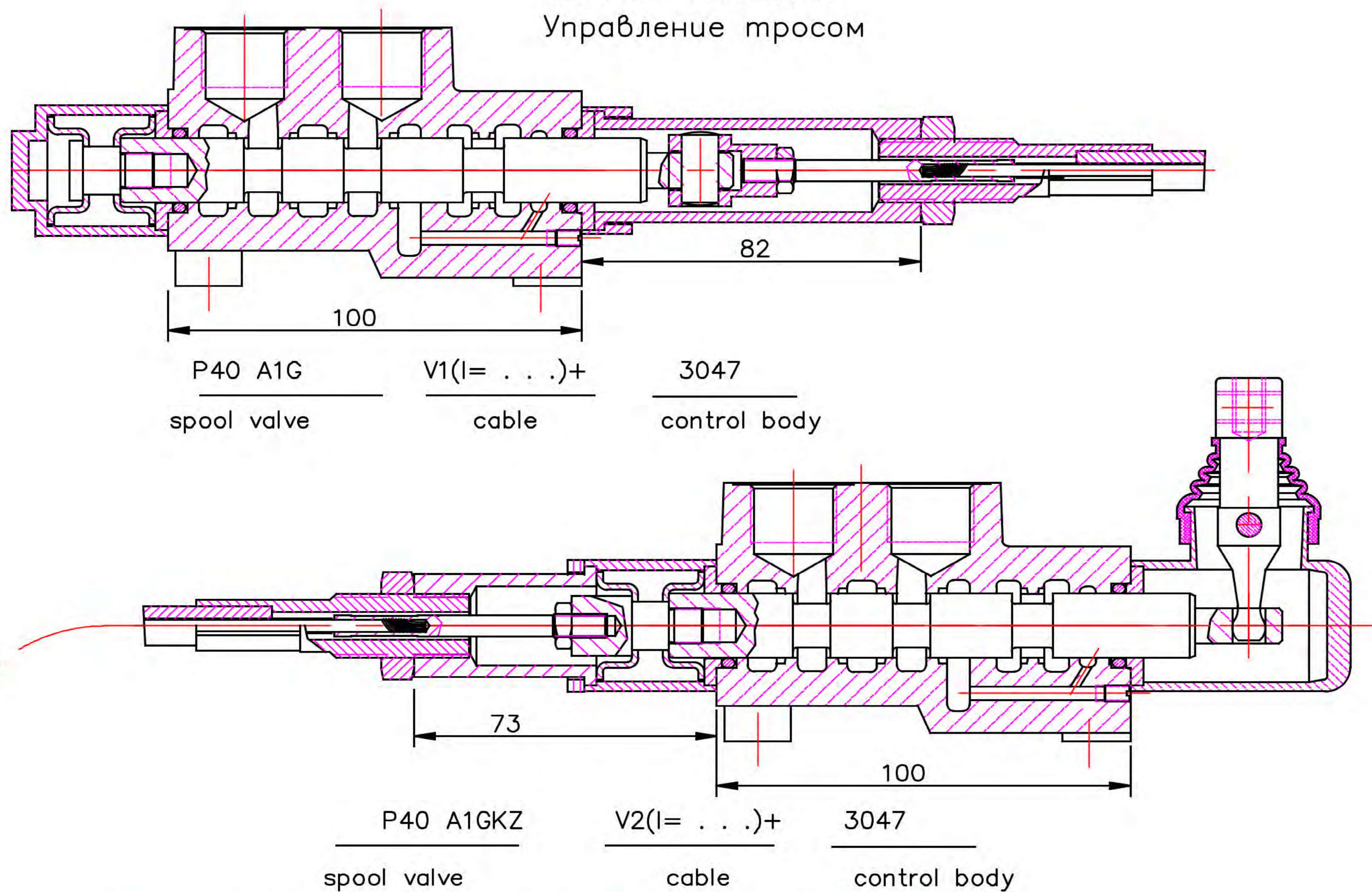

Cable "INDEMAR" Cod. IT 3056 /l=1.00; 1.50; 2.00; 2.50; 3.00 m/
+control body "INDEMAR" code 3047, 3076, 3077

Technical specifications			
	3047	3076	3077
Stroke	13+13 mm	13+13 mm	13+13 mm
Max. load	45 kg	45 kg	45 kg
Level ratio	10:1	10:1	10:1
Lock in neutral	No	No	Yes
Antireverse lock	No	Yes	No
Body colour	Black	Black	Black
Cables type	Heavy Duty	Heavy Duty	Heavy Duty
Operating temperature	-40/+80C	-40/+80C	-40/+80C

High solidity controls for easy mounting on every type of distributor. They can be mounted stand alone or packed together. They use push-pull heavy duty cables that provide a positive smooth operating lever and are manufactured in three different models to meet different needs of Clients.

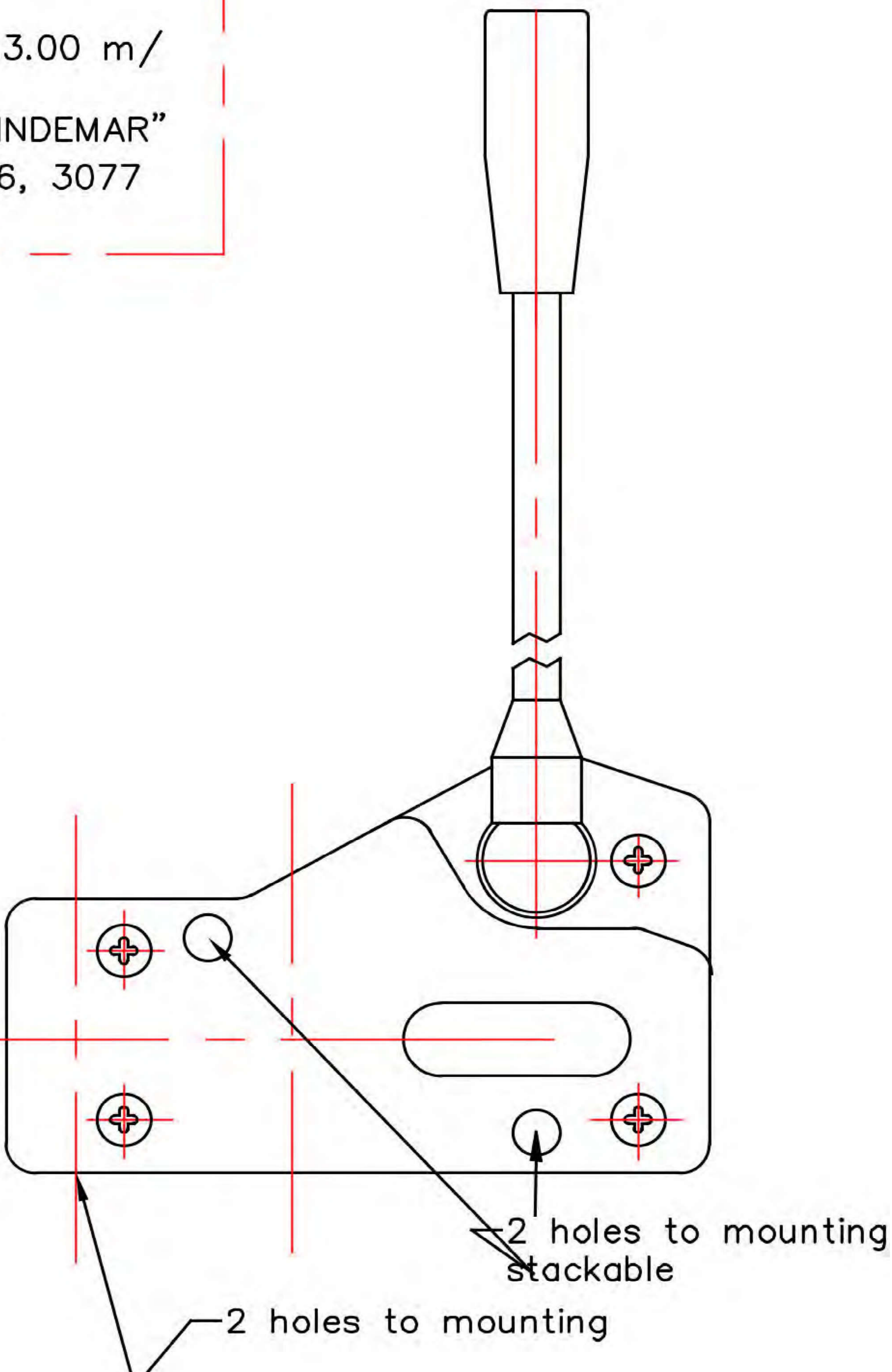

JOYSTICK "+"

This control gives the possibility to operate, at the same time two spools with a "+" movement.

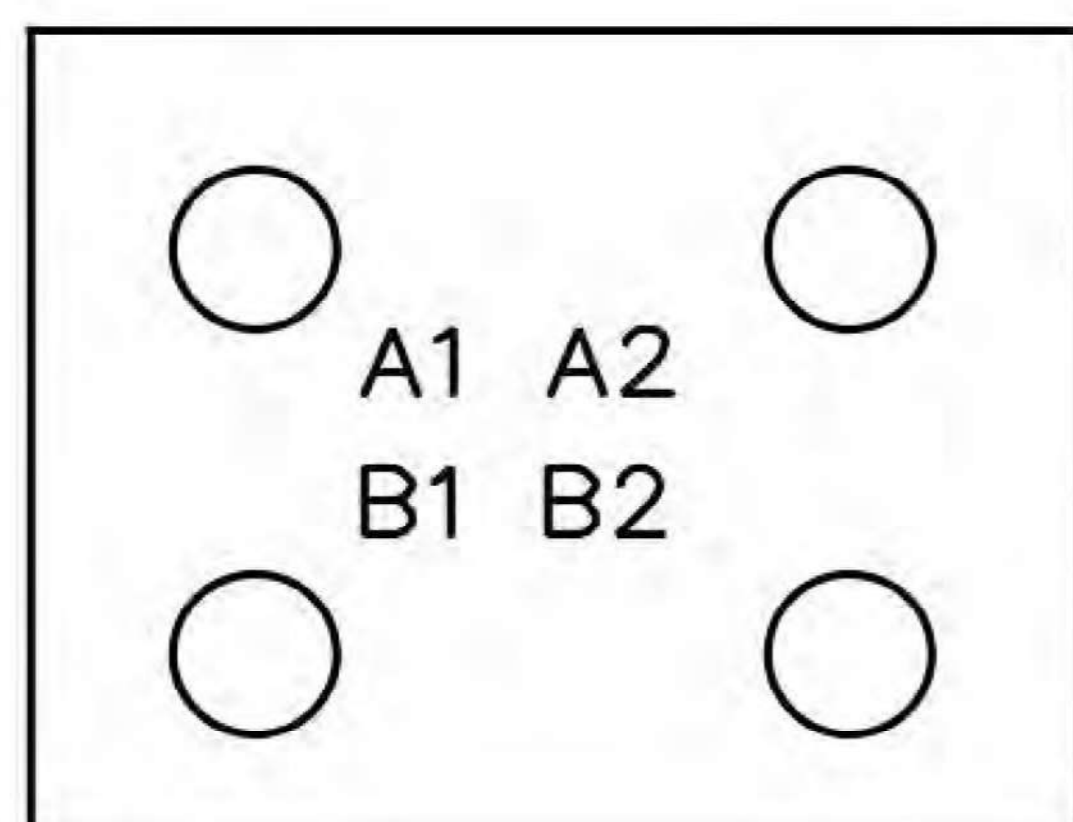
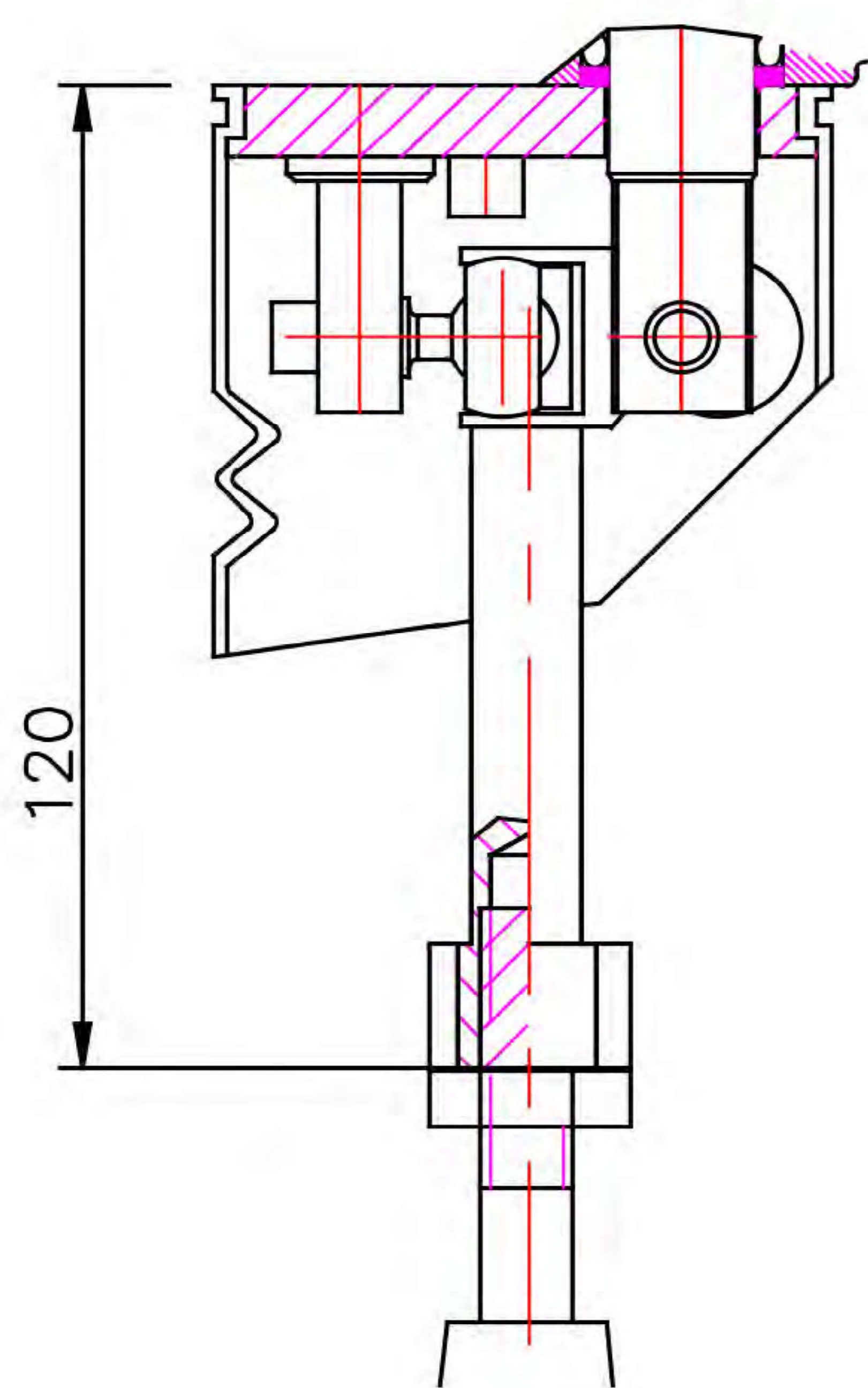

standard version 1

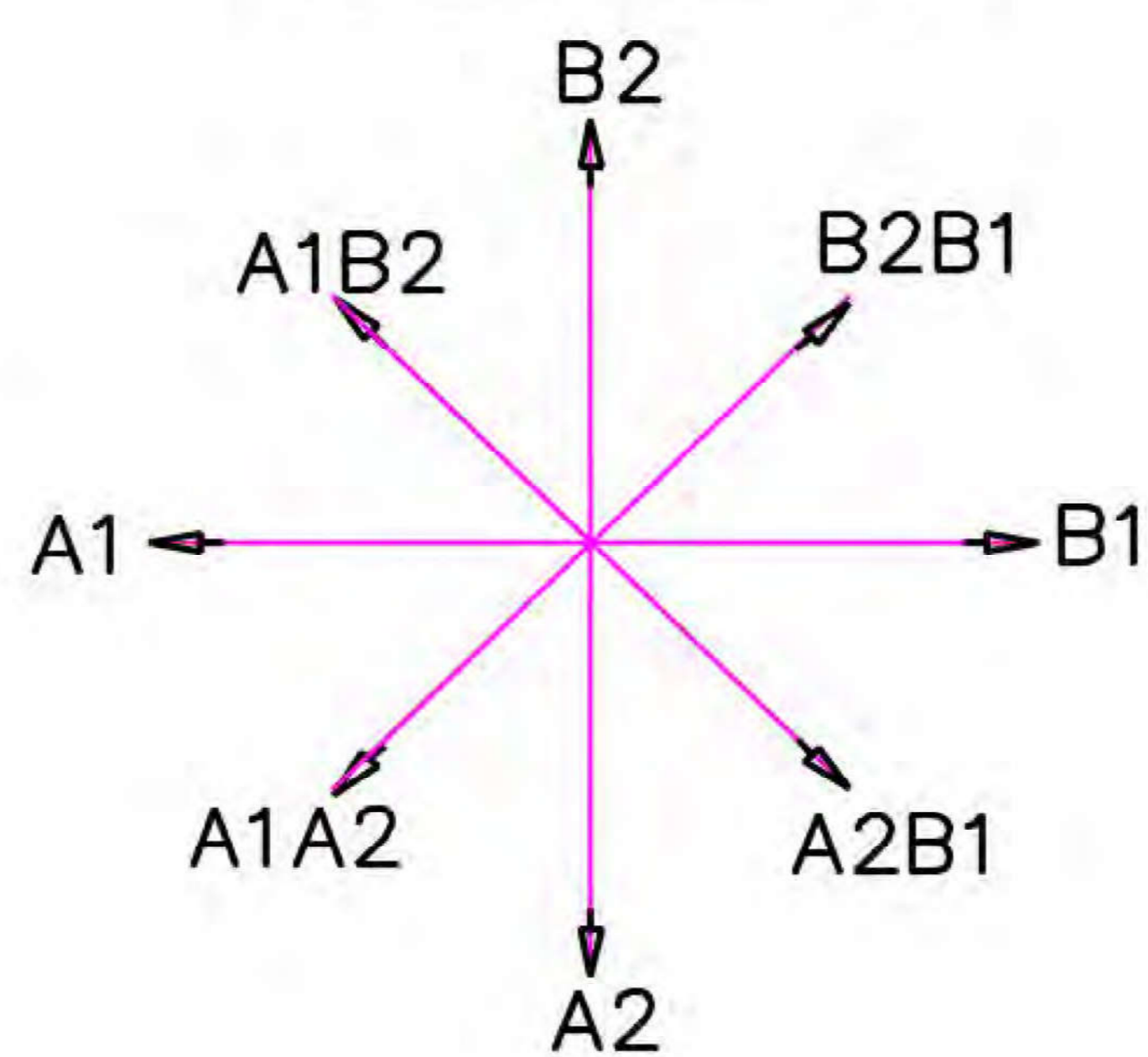
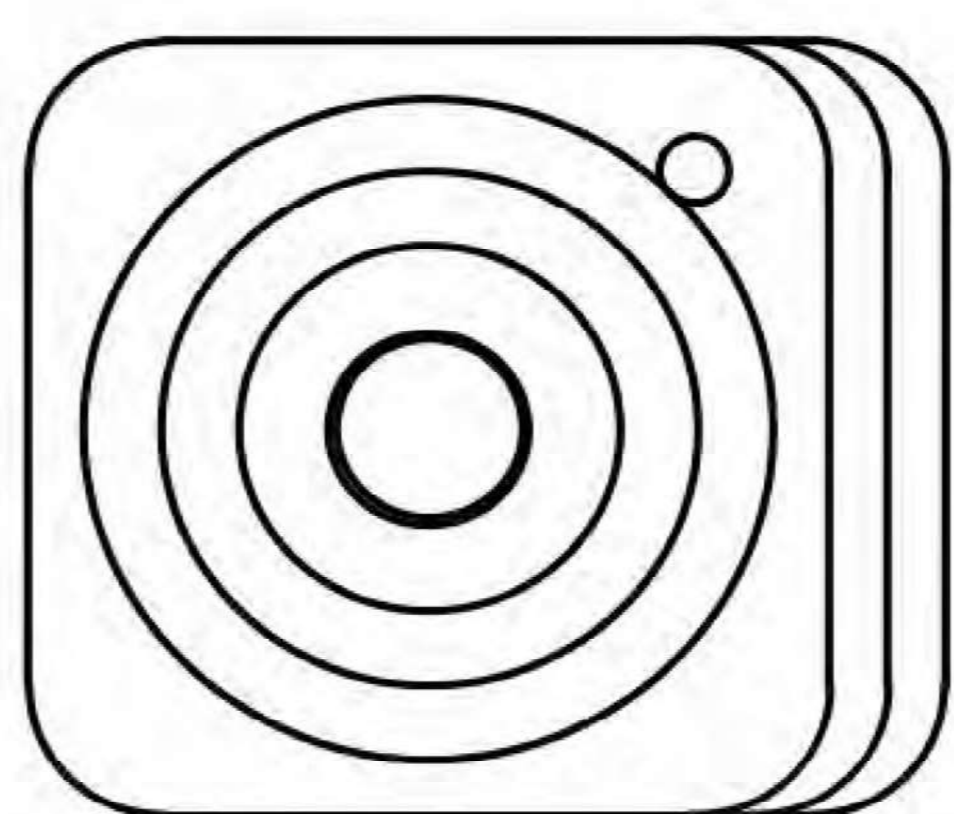

standard version 2

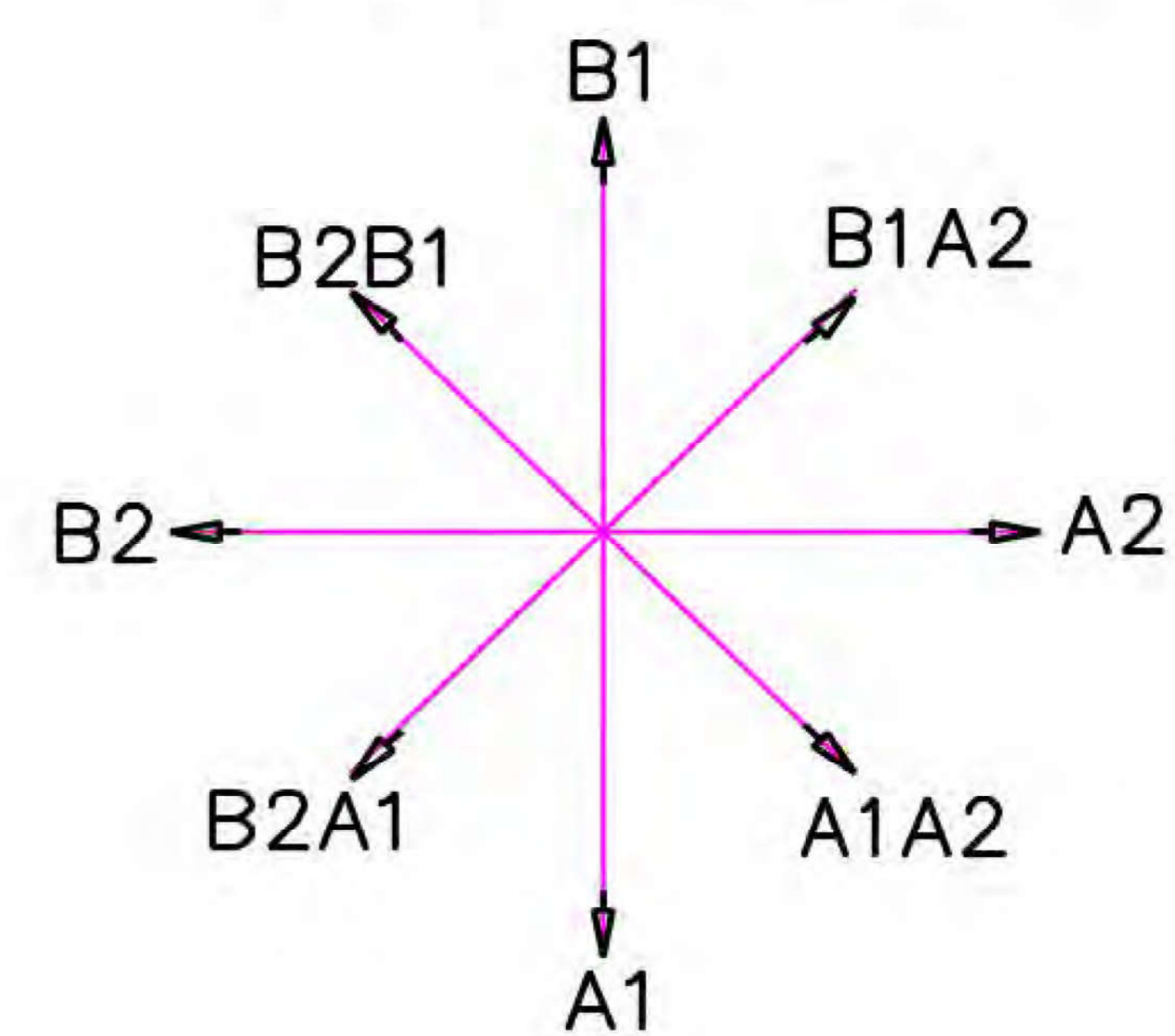
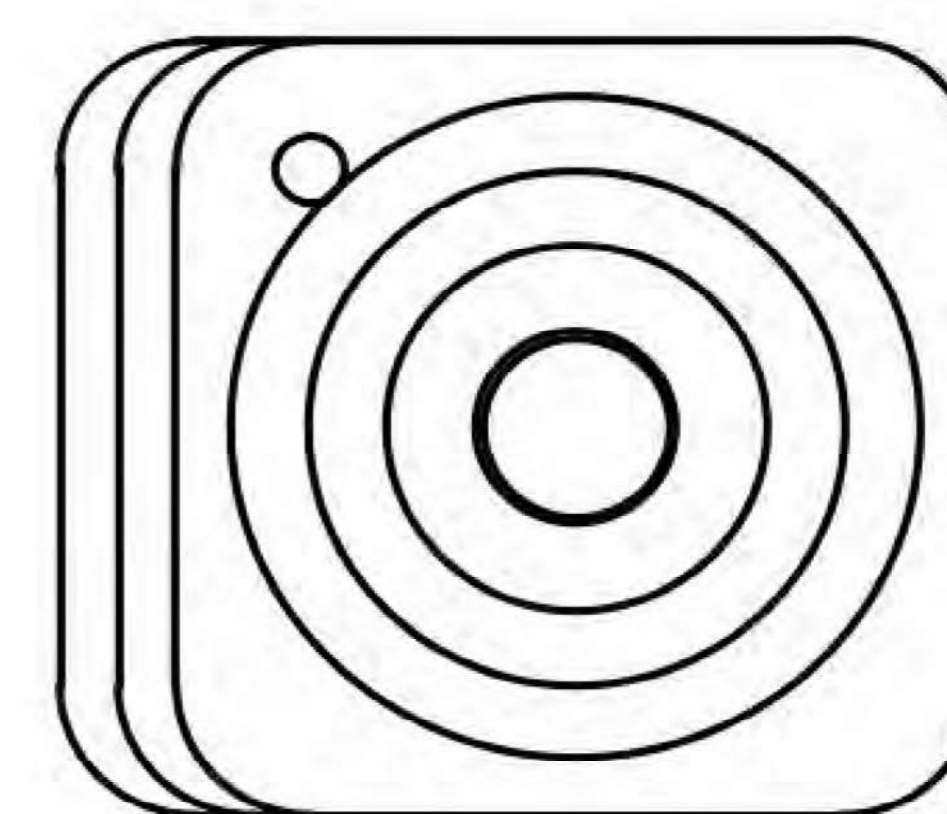

standard version 3

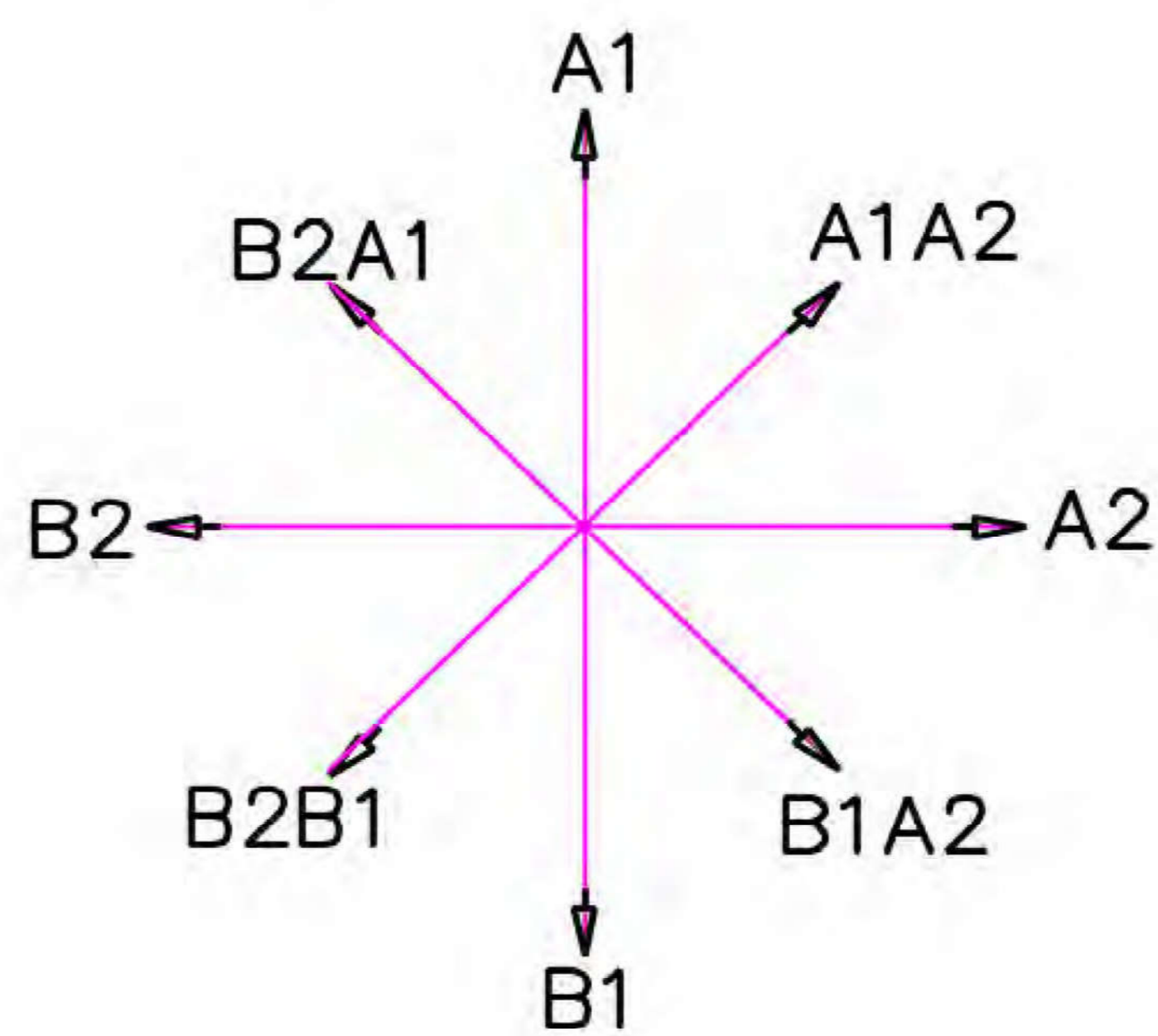
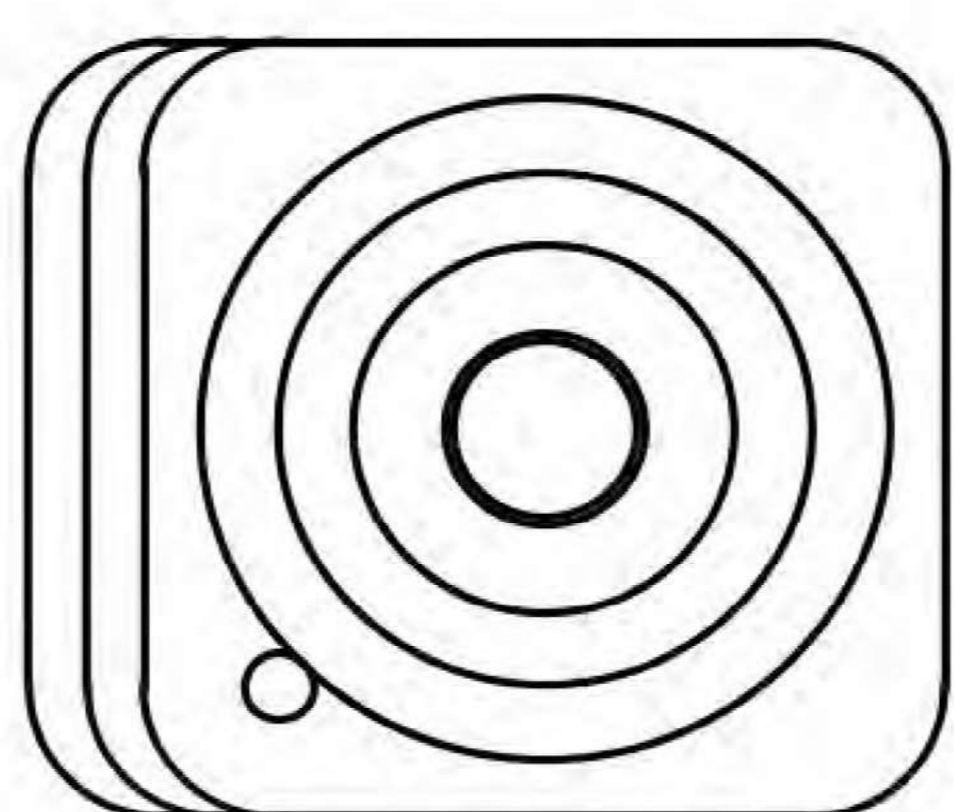

standard version 4

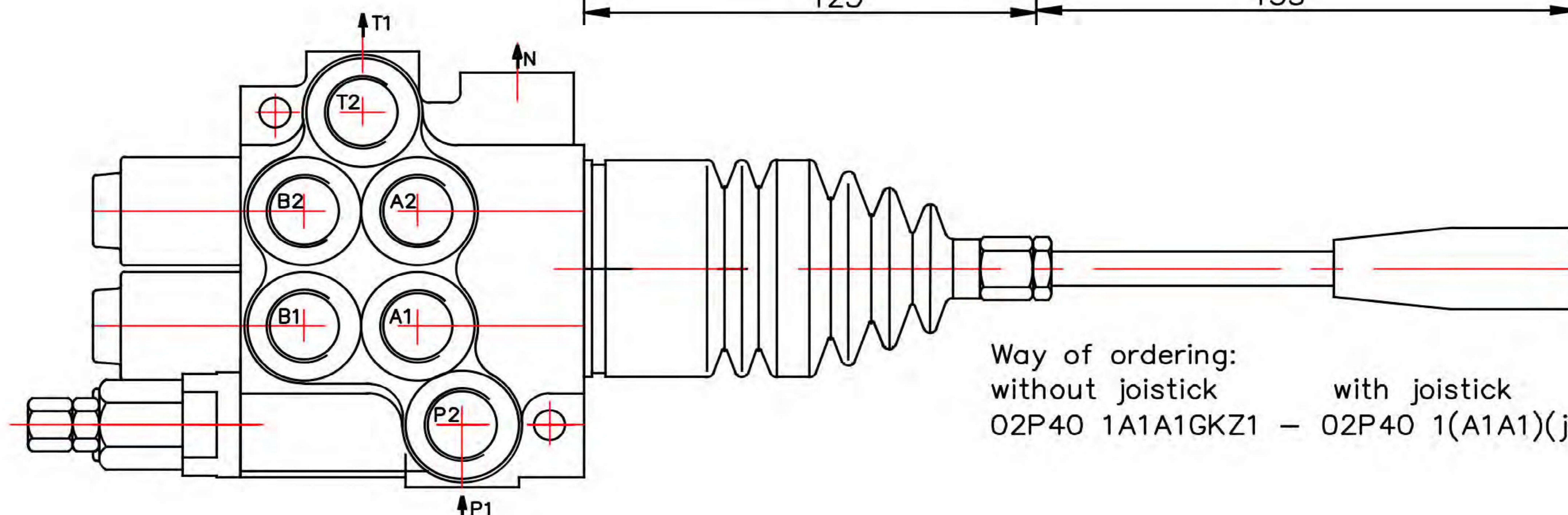
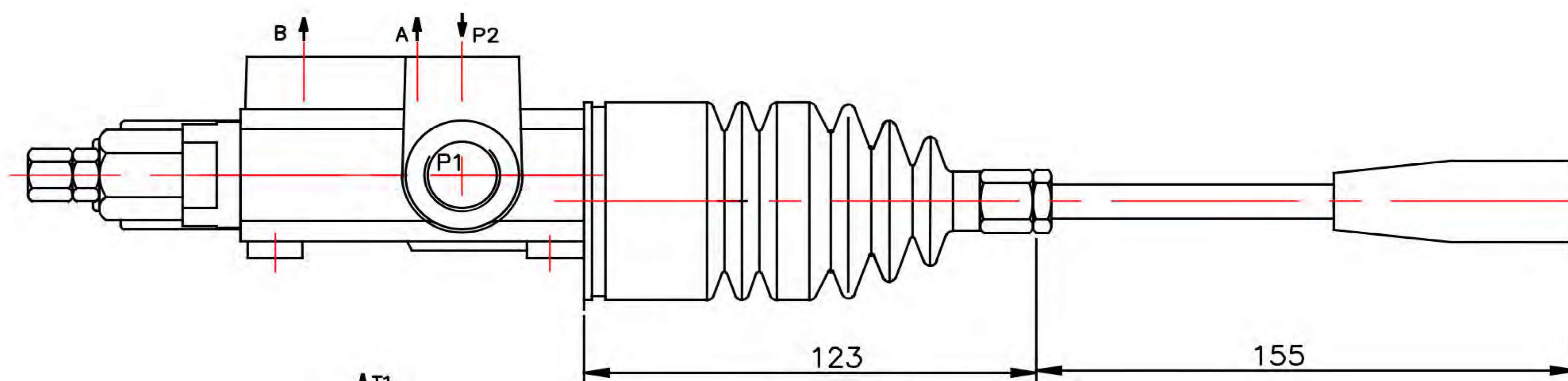
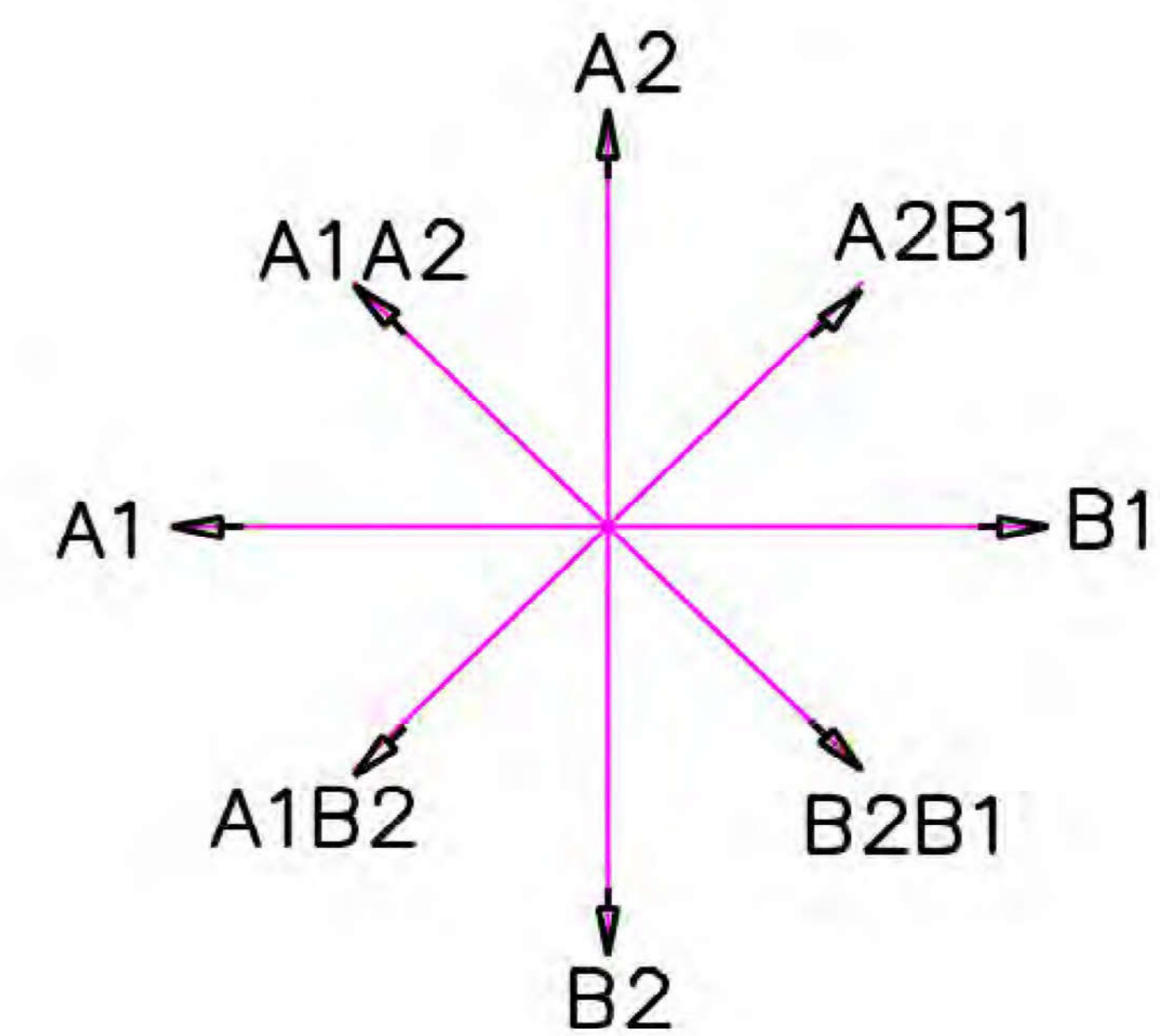
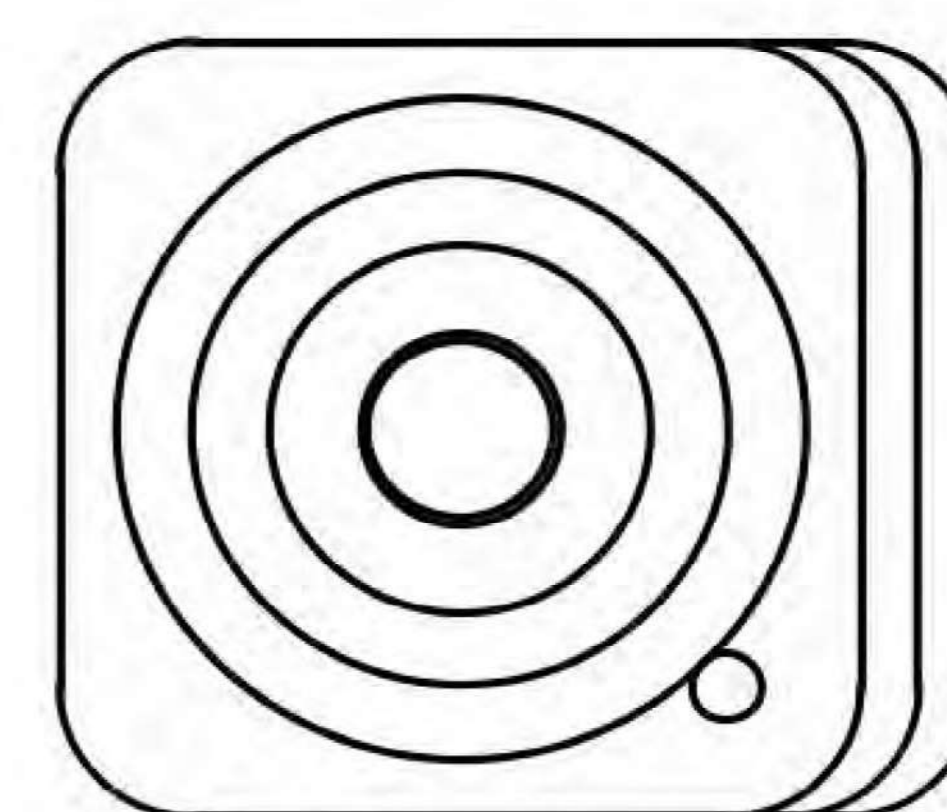

Way of ordering:
 without joystick with joystick
 02P40 1A1A1GKZ1 - 02P40 1(A1A1)(js+3)G

ED3 – electro-hydraulic control ON–OFF
 Электрогидравлический контрол ON–OFF

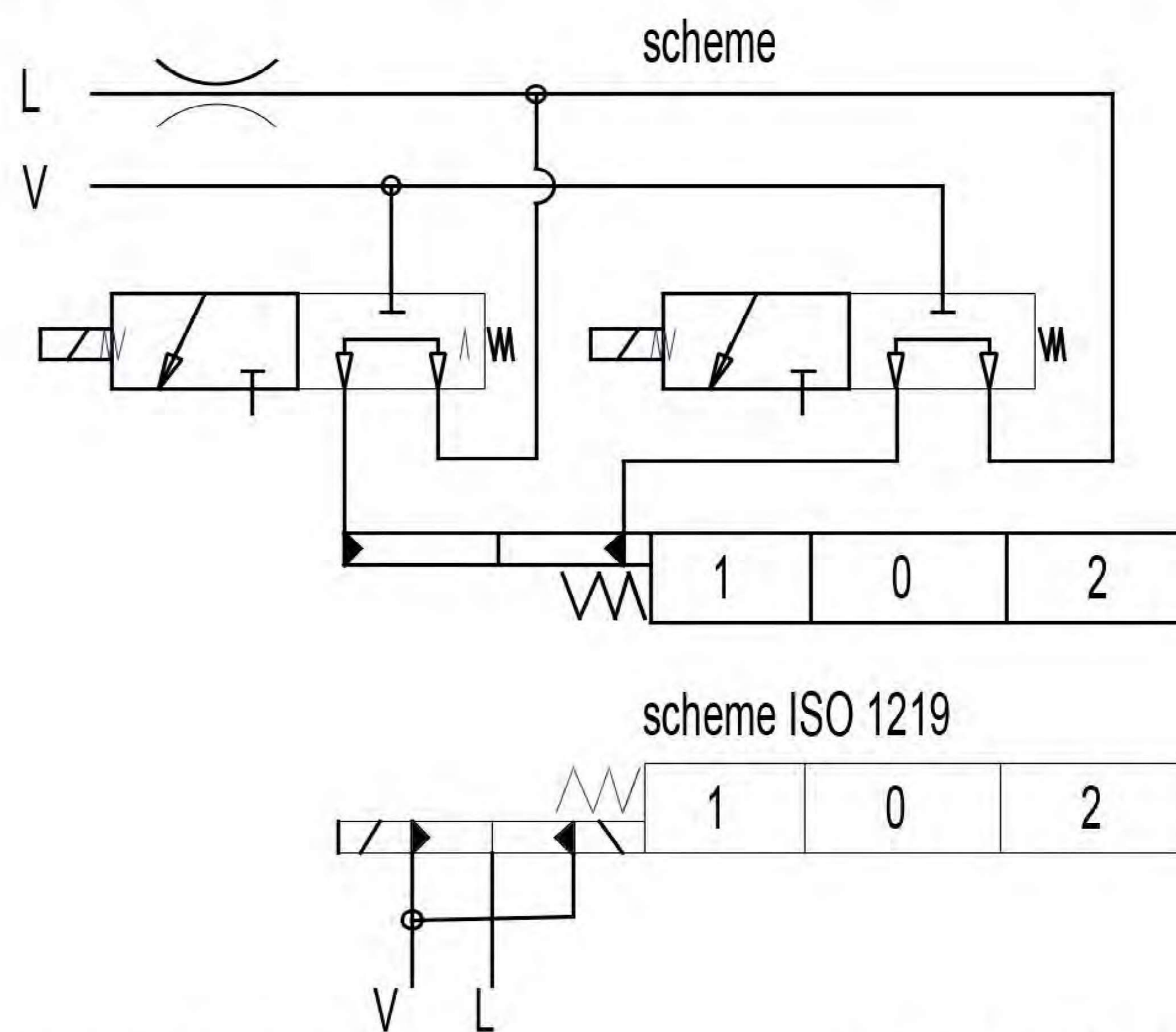
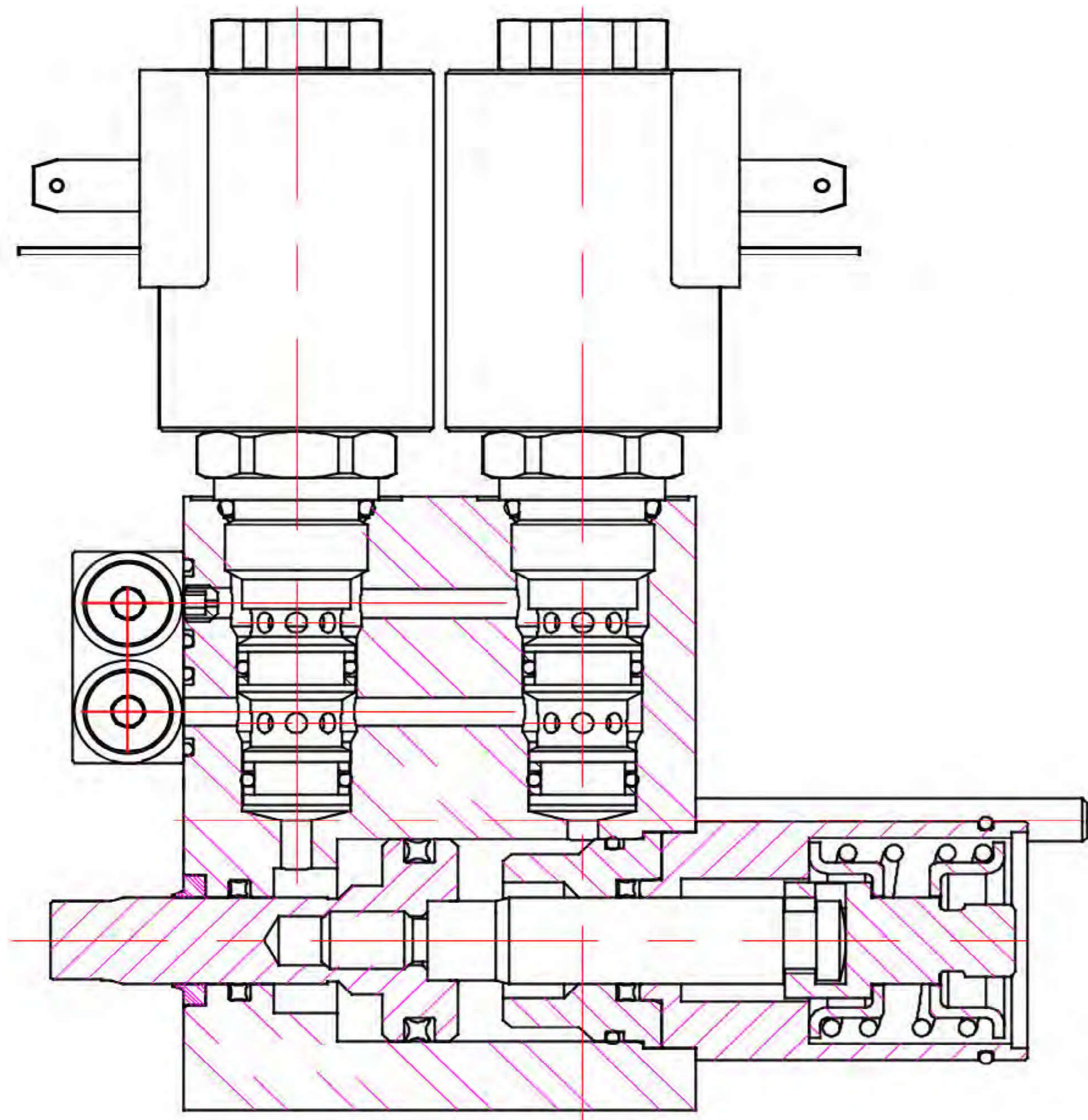

Ordering codes

3-way solenoid valve–SV08–33
 coil P40ED3–G–12VDC
 coil P40ED3–G–24VDC

Operating pressure	min 10 bar(145 psi)
Max operating pressure in L (T line)	max 50 bar(725 psi) 25 bar(360 psi)
Solenoid operating features	
Nominal voltage tolerance	±10%
Power rating	24W
Duty cycle	100 %

Collector kit for external pilot and drain – CEED...(1,2,3 ...)
Коллектор для внешнего питания управления и слив

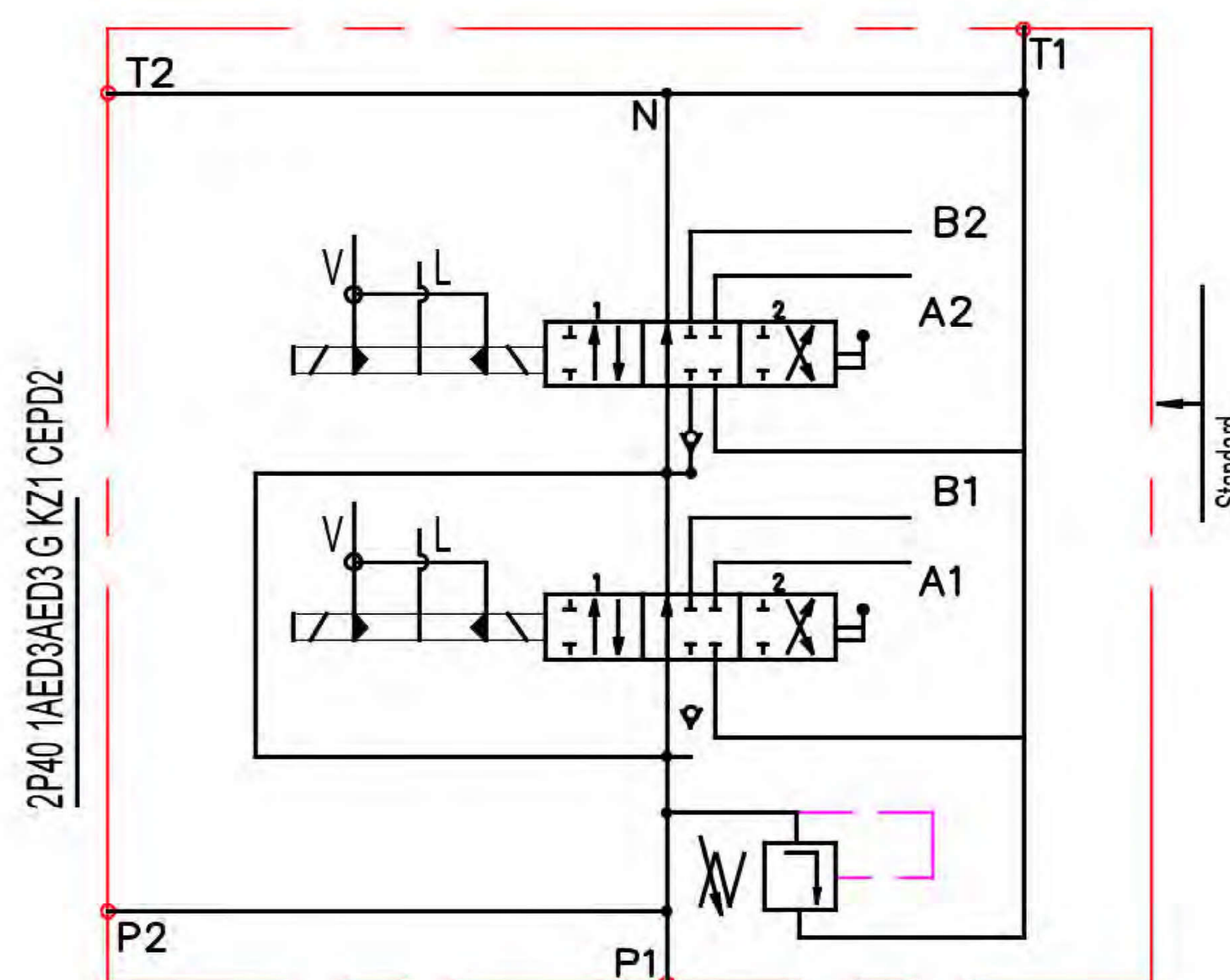
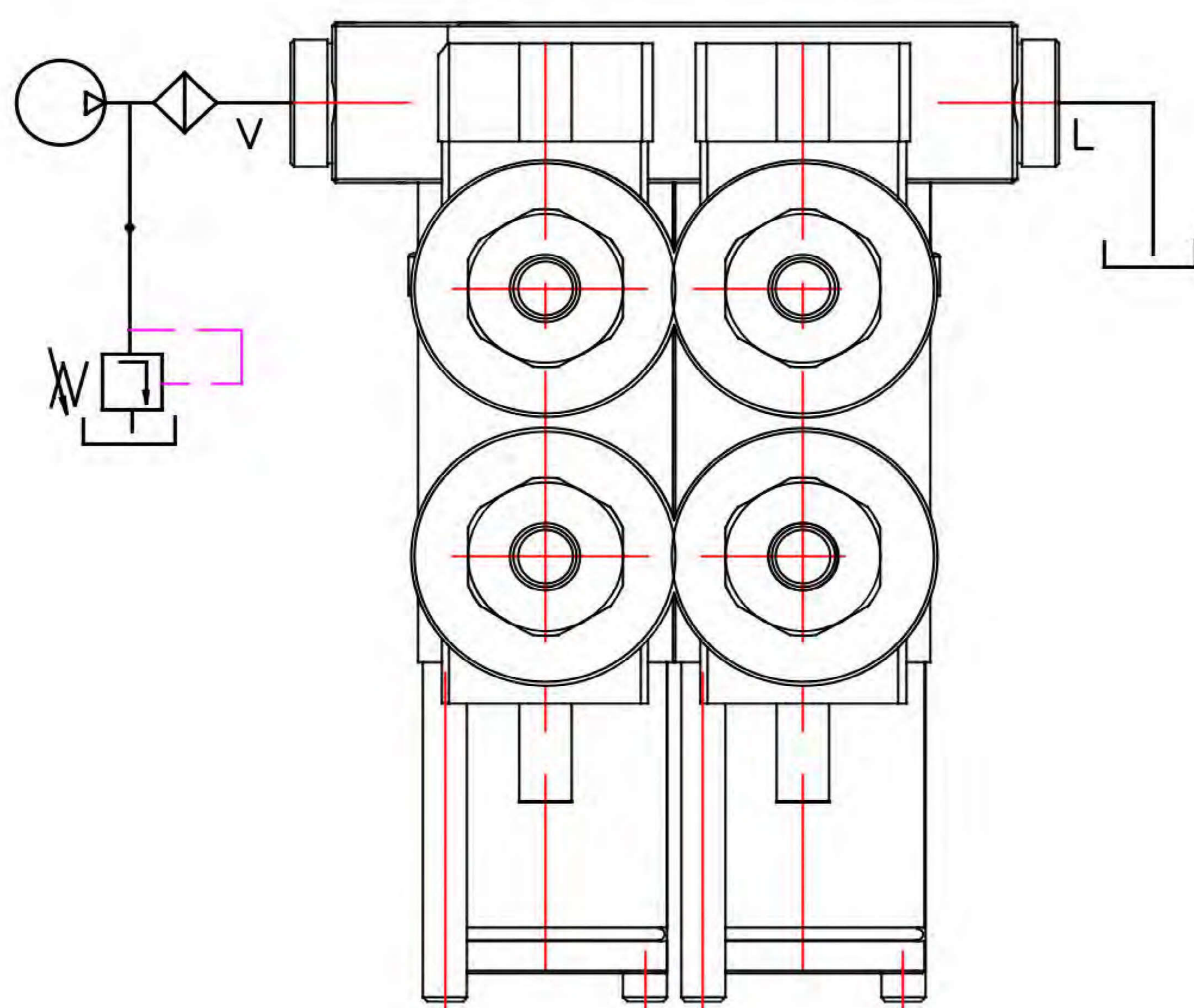

Ordering example

2P40–1A1ED3A1ED3 G KZ1–CEED2–12VDC

Ordering codes (BSP threads)

CEED1P40	Kit for 1 section
CEED2P40	Kit for 2 section
CEED3P40	Kit for 3 section
CEED4P40	Kit for 4 sektion
.....	

ED3 – electro-hydraulic control ON-OFF
 Электрогидравлический контрол ON-OFF

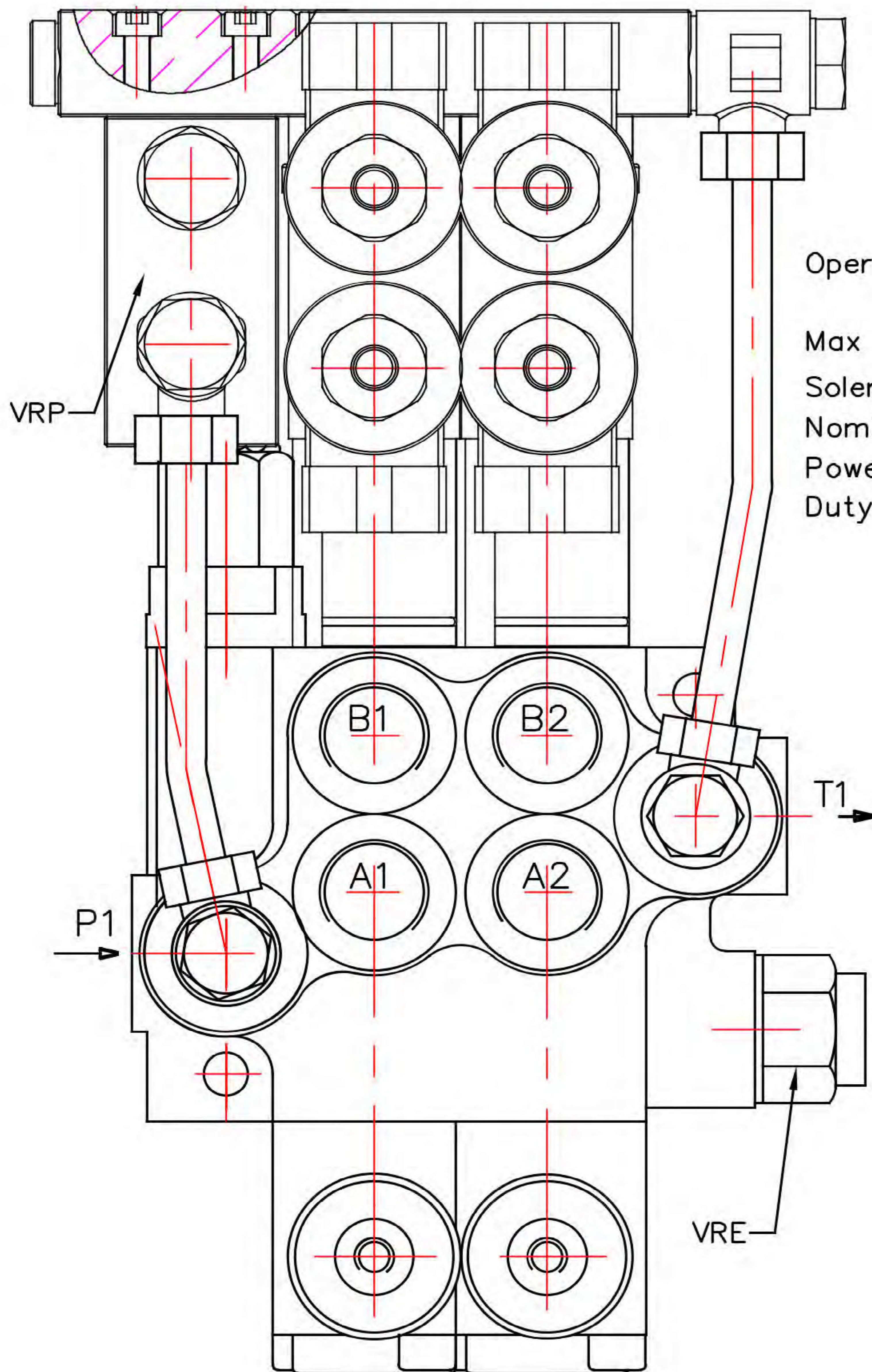

Order codes

3-way solenoid valve-LSV2-08-3C
 coil P40ED3-G-12VDC
 coil P40ED3-G-24VDC

Operating pressure	min 10 bar(145 psi) max 50 bar(725 psi)
Max operating pressure in L (T line)	25 bar(360 psi)
Solenoid operating features	
Nominal voltage tolerance	±10%
Power rating	24W
Duty cycle	100 %

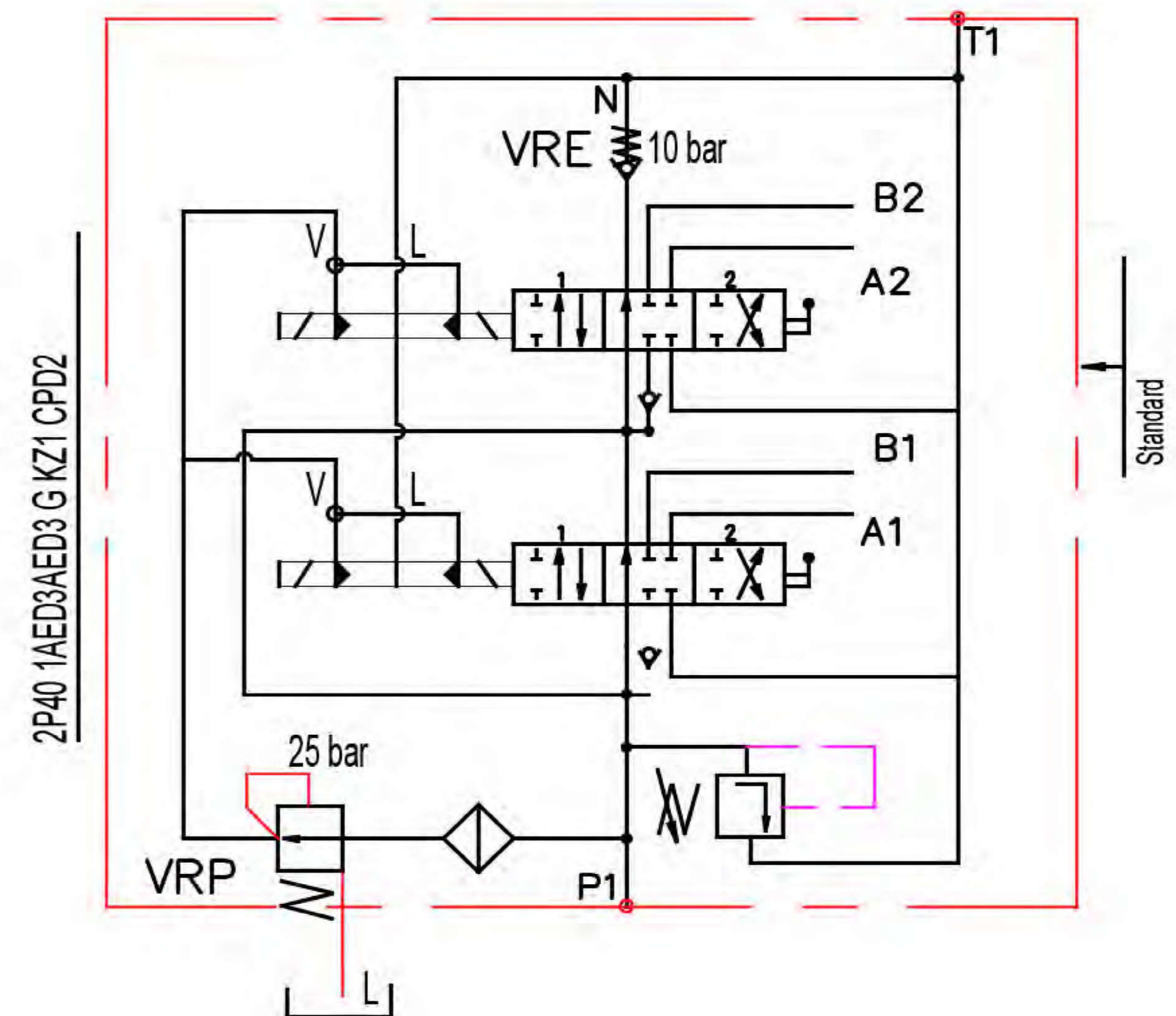

Ordering example

2P40-VRP- 1A1ED3A1ED3 G KZ1-CED2-VRE-12VDC

Colector kit

- CED1
- CED2
- CED3
- CED4
-

**Ordering codes
 BSP threads**

- Kit for 1 section
- Kit for 2 section
- Kit for 3 section
- Kit for 4 sektion

**Back pressure valve VRE-P40
 Клапан подпорный на слив**

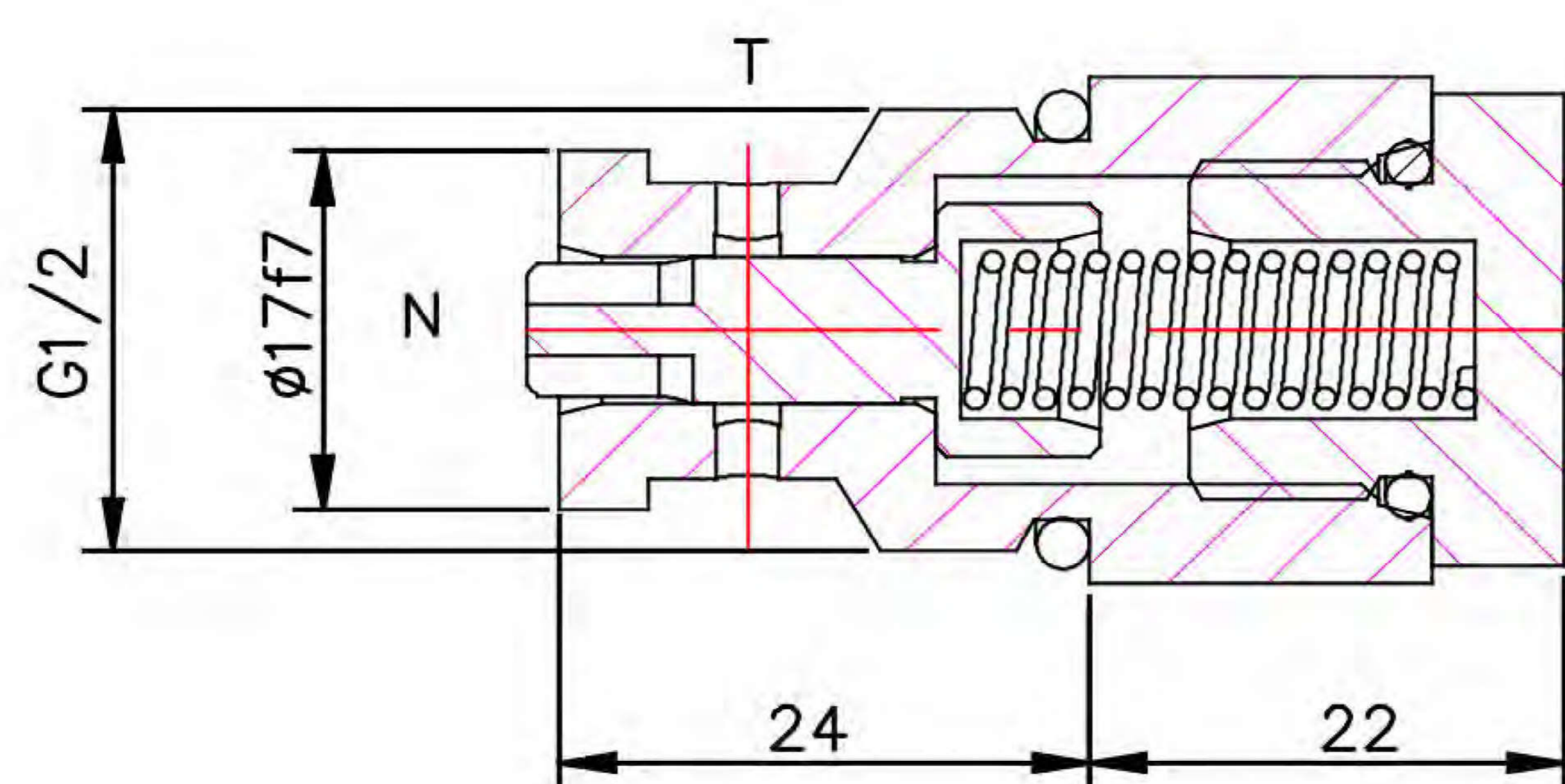

Pressure drop N-T

